

BEST CHOICE

FOR PROCESS AND TEMPERATURE CONTROL

Application: Control temperature, humidity, pressure, flow and PH.

FY series controllers are microprocessor based controllers. Which have been designed with high accuracy input, various output selection, useful options and good reliability at a competitive price.

FY series use "PID+FUZZY" algorithm to implement excellent control. The output status is displayed on the built in "Bar-Graph" display.

FY series not only provide the basic control output selections but also plus advanced options such as "Motor Valve Control", "SCR/TRIAC Trigger", and "Programmable RAMP/SOAK".

FY Series support MODBUS protocol. Communication with HMI is more convenient. New additional HBA function with competitive price, user can upgrade system safety easy.

Available in 5 sizes, the models and sizes are as below:

FY400:48X48mm (DIN 1/16) FY600/800:48X96mm (DIN 1/8)
FY700:72X72mm (DIN 3/16) FY900:96X96mm (DIN 1/4)



FY400

FY700

FY800

FY900

FY600

CE approval & free power

All models get CE and UL approval.
Operate on any voltage from AC 85~265V at 50/60Hz.
DC 24V is also available(optional function).

IP65 Proof

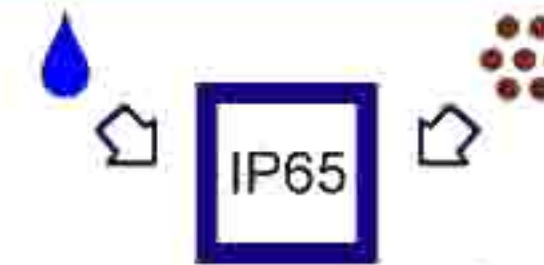

IP65 dust & water proof is available for all models(optional function).

Heater Break Alarm (HBA)



Heater current flowing through CT can be displayed on controller.
If heater current is less than HBA set value, AL1 will be activated(optional function).

Autotuning (AT)

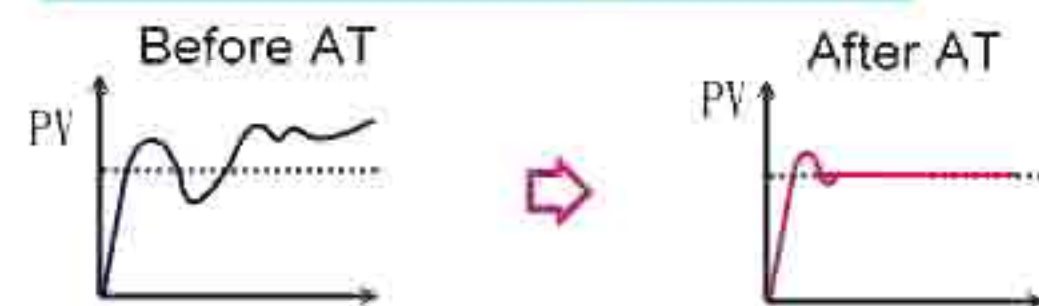

AT Function can calculate the optimize PID value for your control system, without trying and error manually.

MODBUS Communication

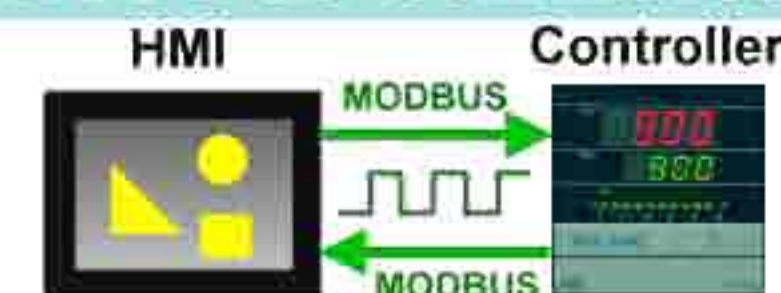

FY series support both MODBUS RTU and MODBUS ASCII protocol.
Communication between controller and HMI or other equipment is more convenient(optional function).

Auto/Manual mode



Conveniently switched between auto/manual output mode by clicking "A/M" key(except "FY400").

Various Indication Lamps



Real time monitor the status of output (OUT1/OUT2), AT, alarm(AL1/AL2/AL3), manual output(MAN) and program(PRO).

Bar-Graph



Output percent displayed on the bar-graph in 10 LEDs resolution(except "FY400").

High Accuracy

Input with 14bit A/D resolution, 0.2% accuracy of FS.
Built in "AutoZero-AutoSpan" function keep good accuracy.

Data Lock Function

All parameters are separated in 3 operation levels.
Each parameter can be hidden or locked to prevent unauthorized changes.

Various I/O Types

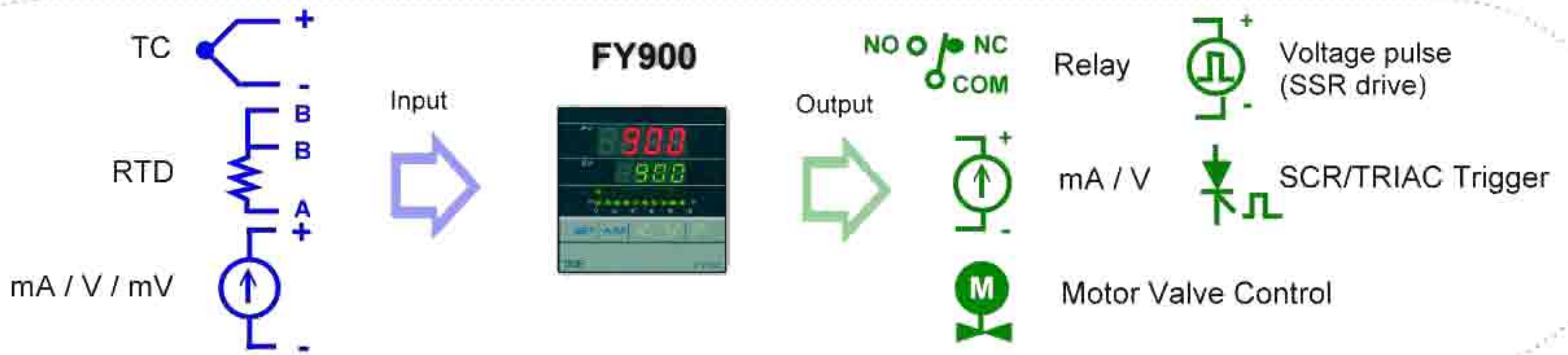

Peripheral Options

Remote SV

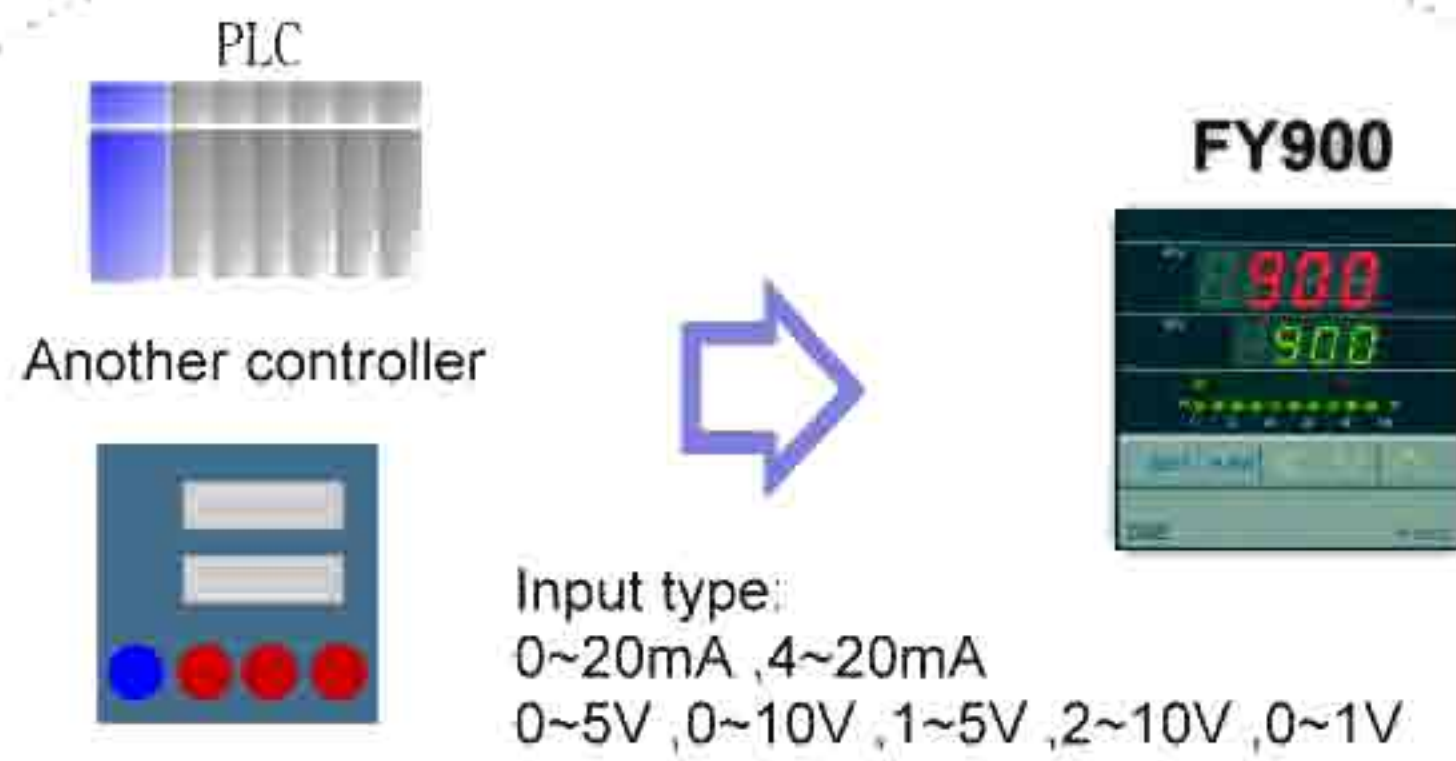

Transmission

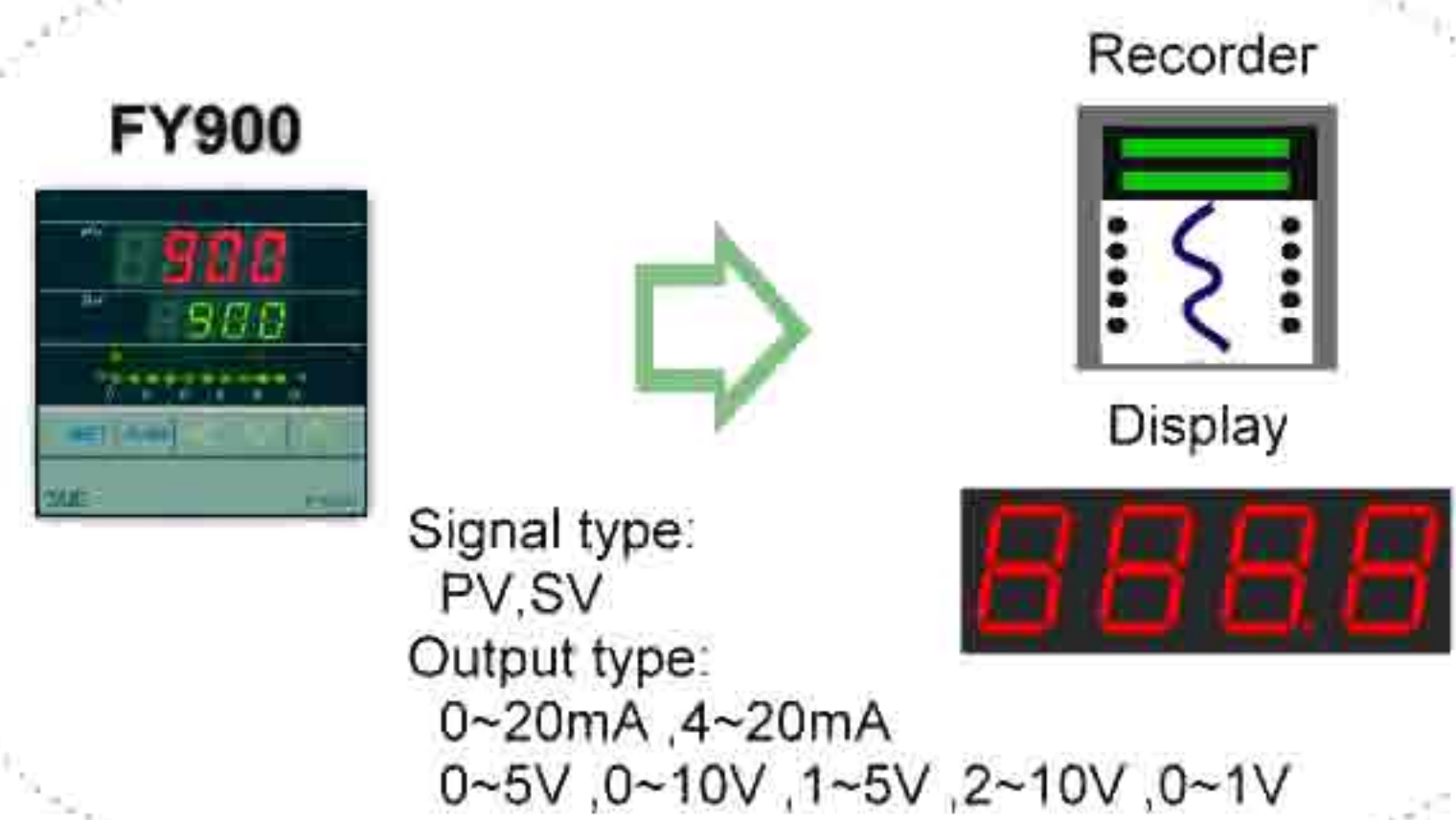

Communication

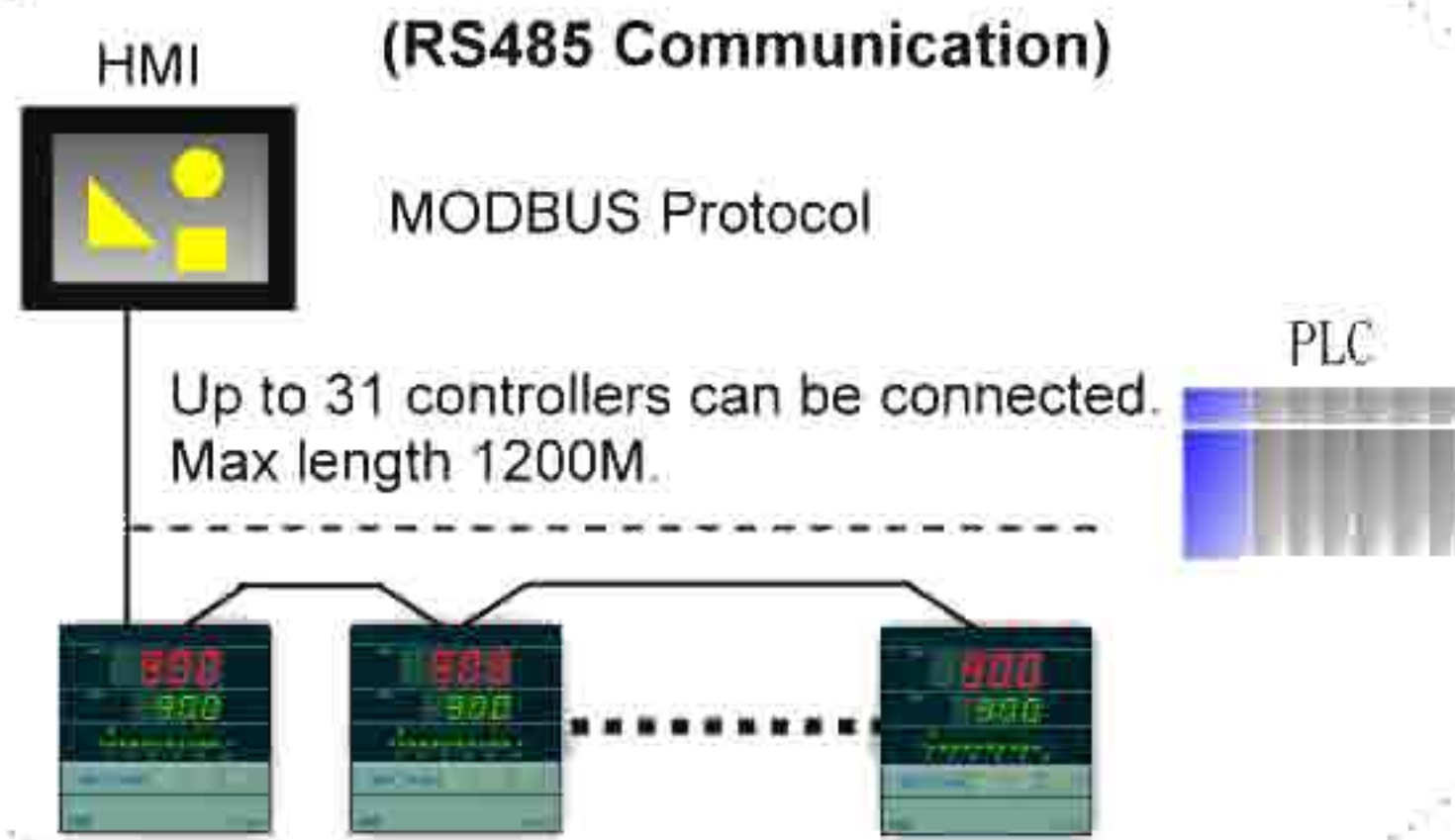

Communication

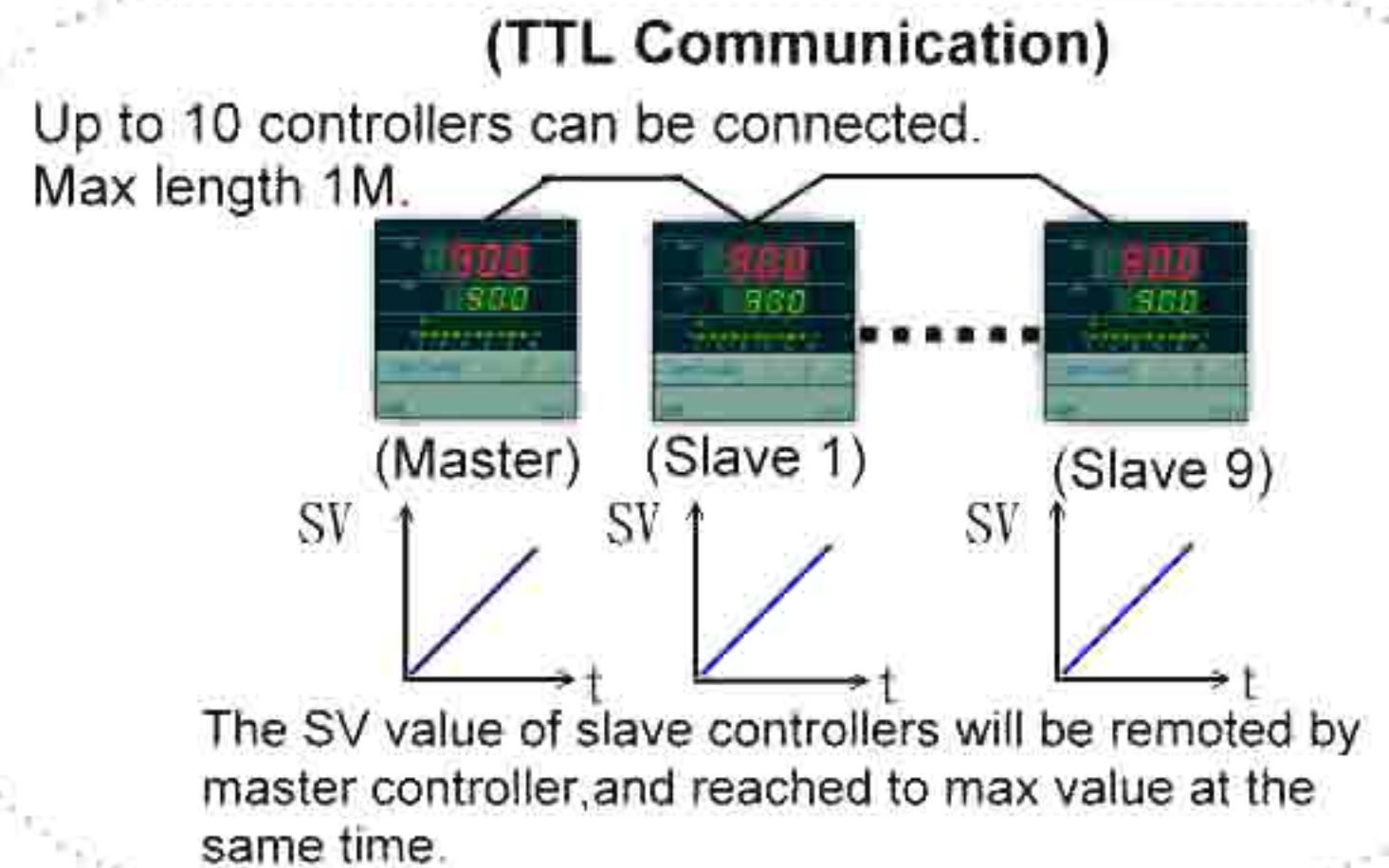

Special Application

Ramp/Soak Program

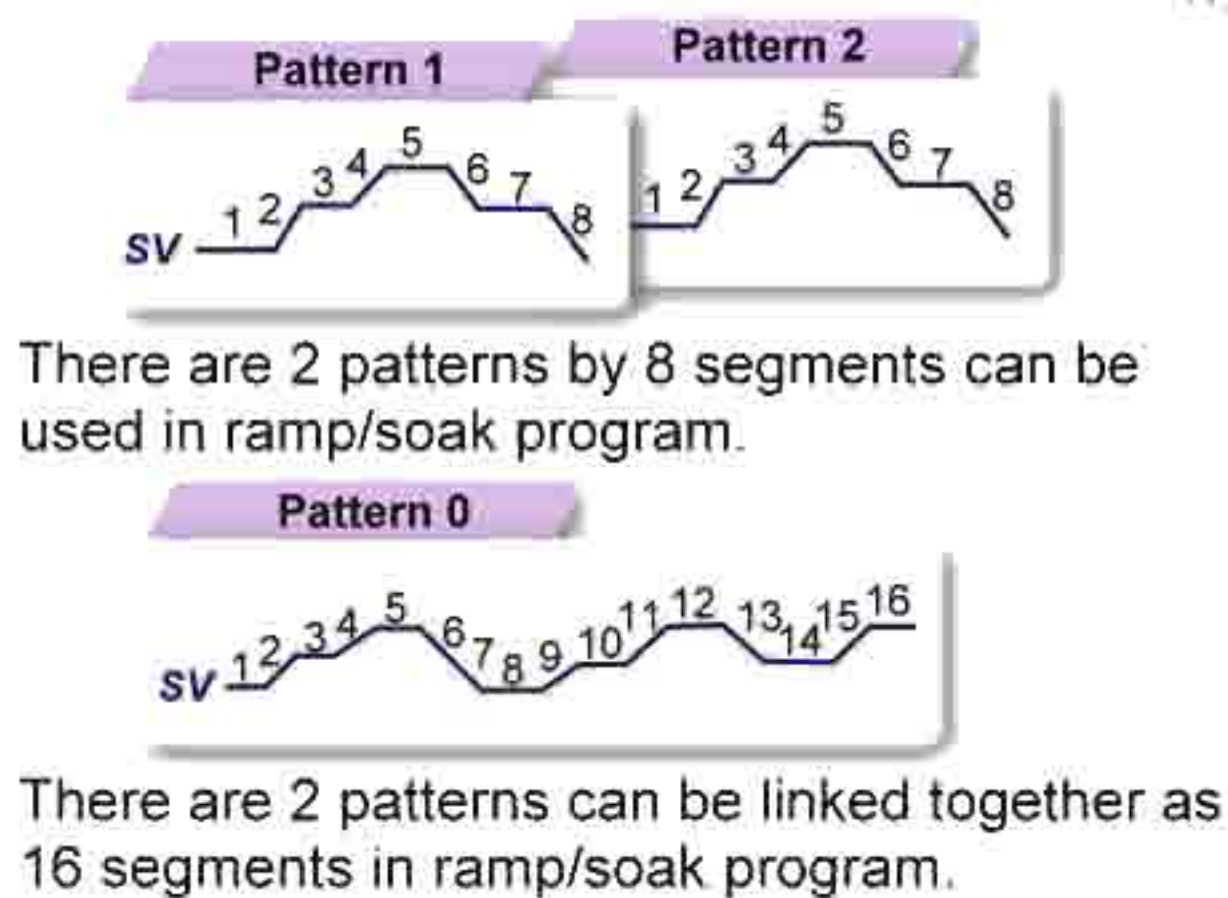

Heating and Cooling Control

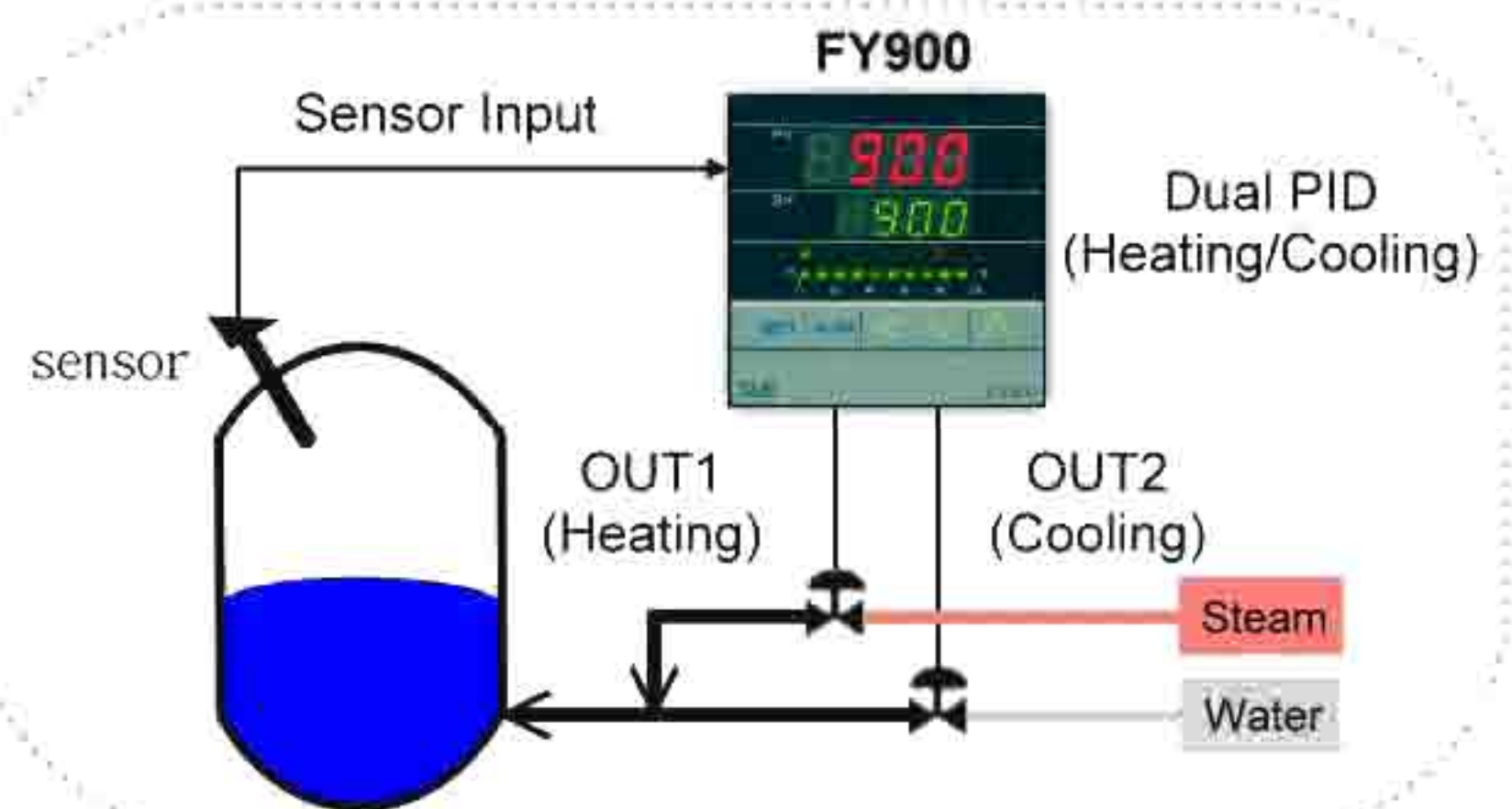

Motor Valve Control

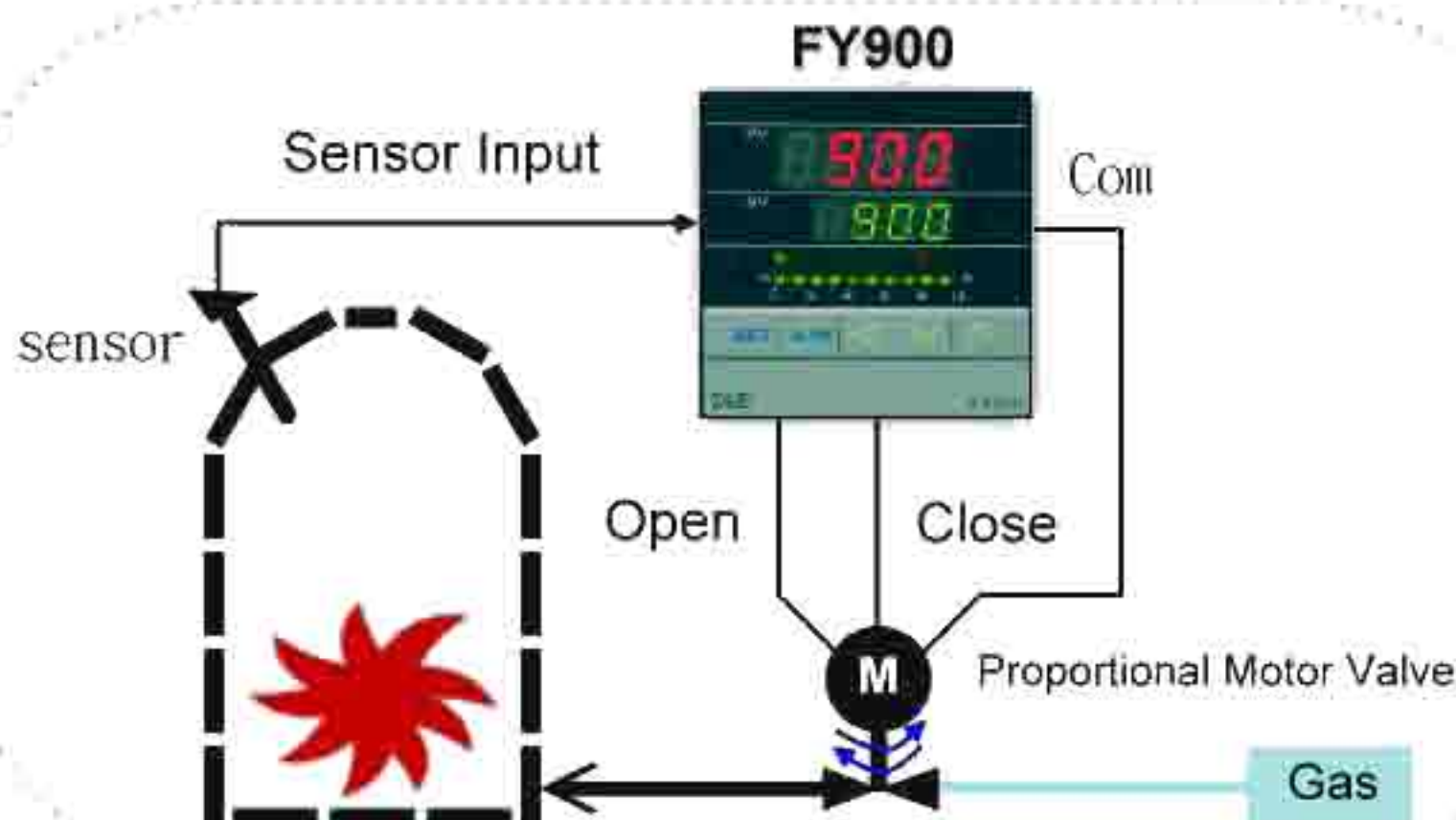

SCR/TRIAC Trigger

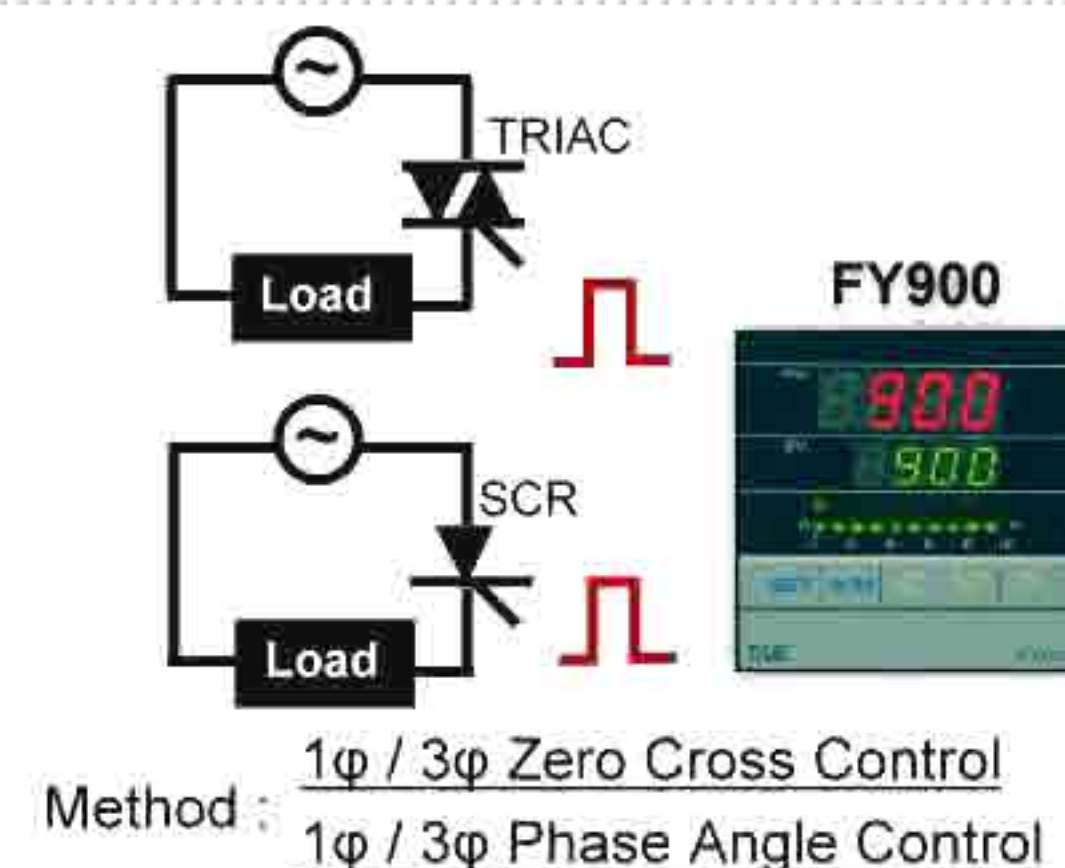

Excellent Control

Control Method

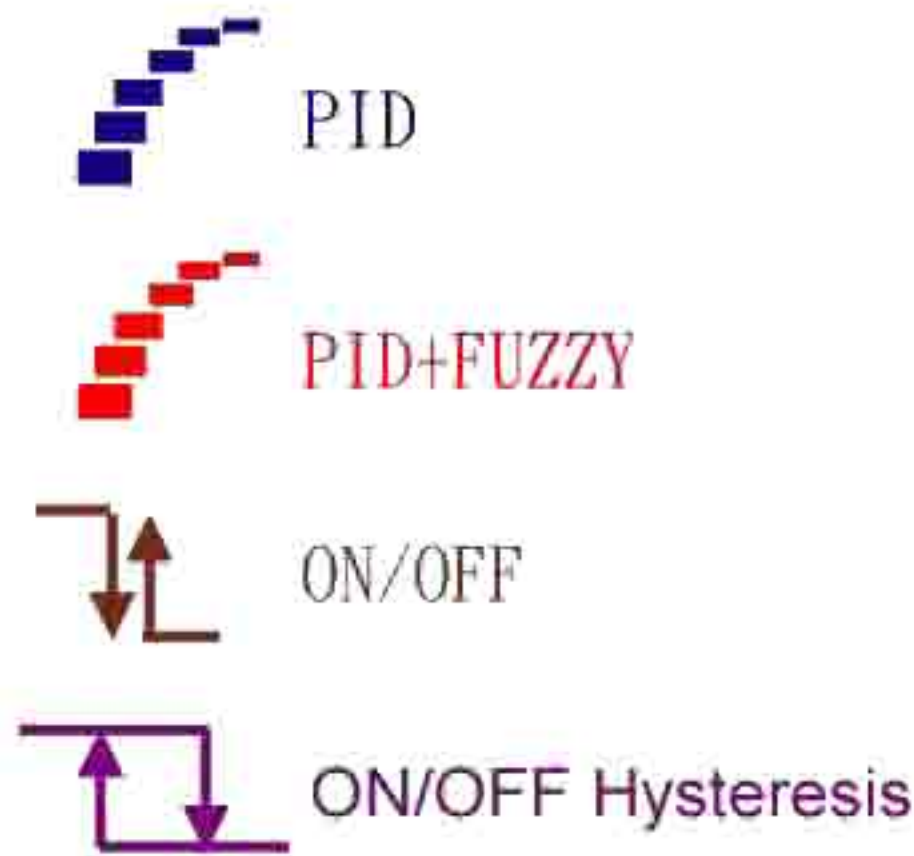

Fuzzy Logic

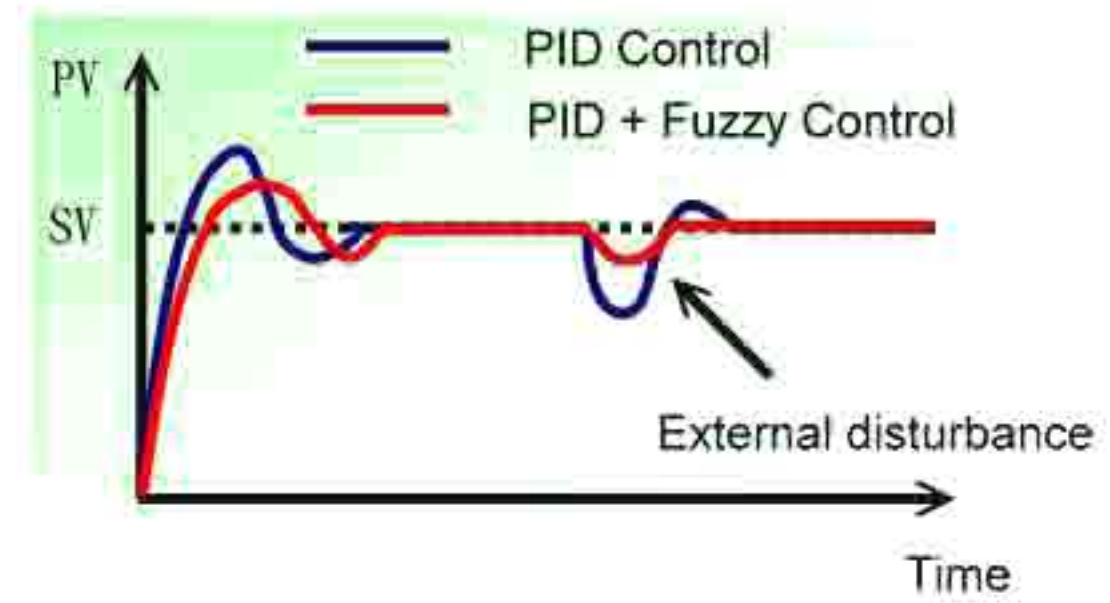

Built in fuzzy logic suppress the overshoot due to SV changes or external disturbance.

Autotuning (AT)

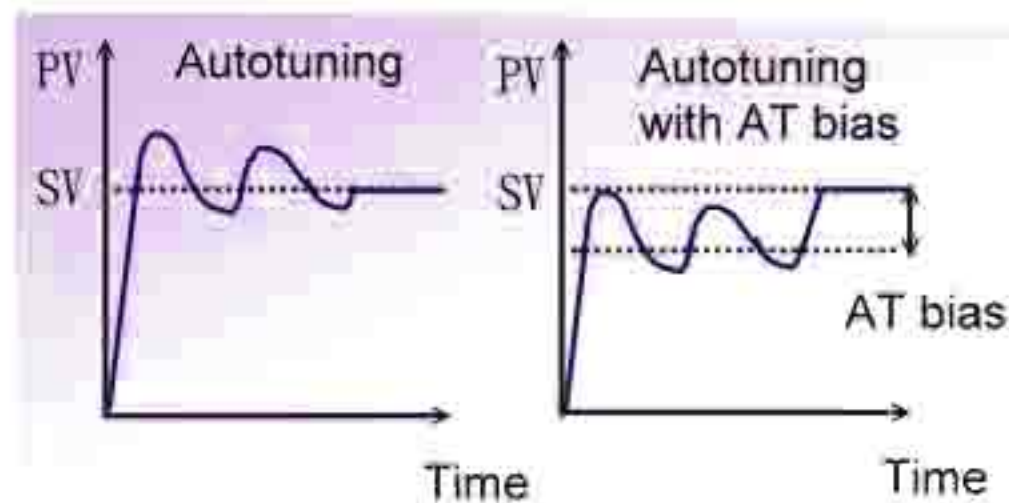

When autotuning acts, it will make PV hunting 1~2 cycle to calculate optimize PID value. To protect user's device, FY series controller can perform PV hunting below SV by setting AT bias value(ATVL).

Limit Setting

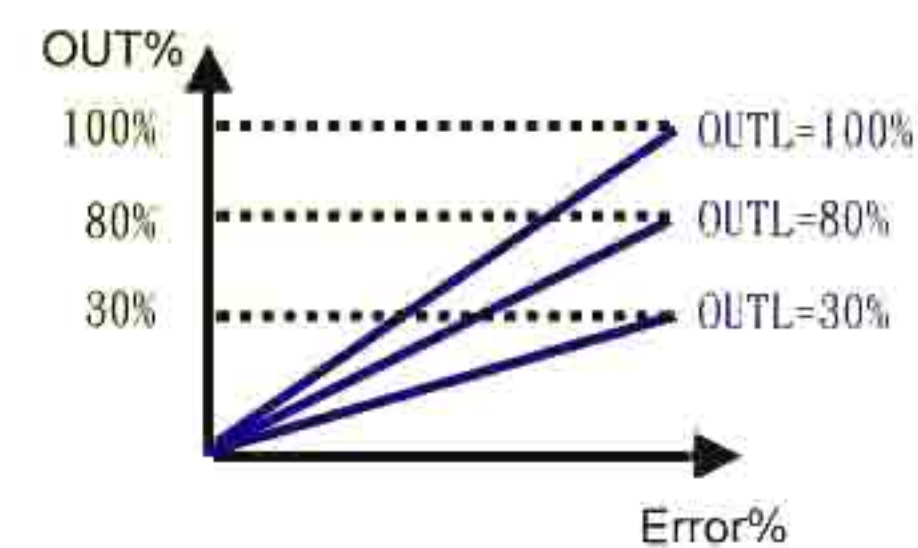

Built in output limit function. Use this function to get different gradient output and set limit for output.

Convenient Installation

Easy Mounting

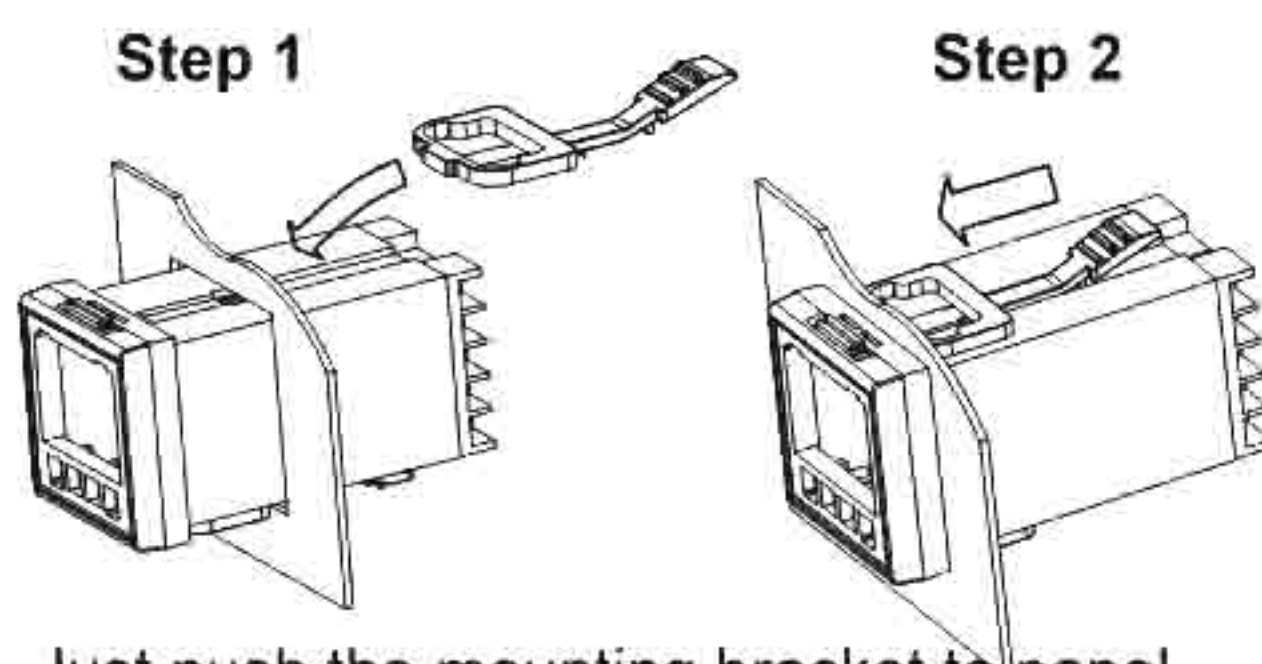

Just push the mounting bracket to panel. Without using any screws.

Saving Space

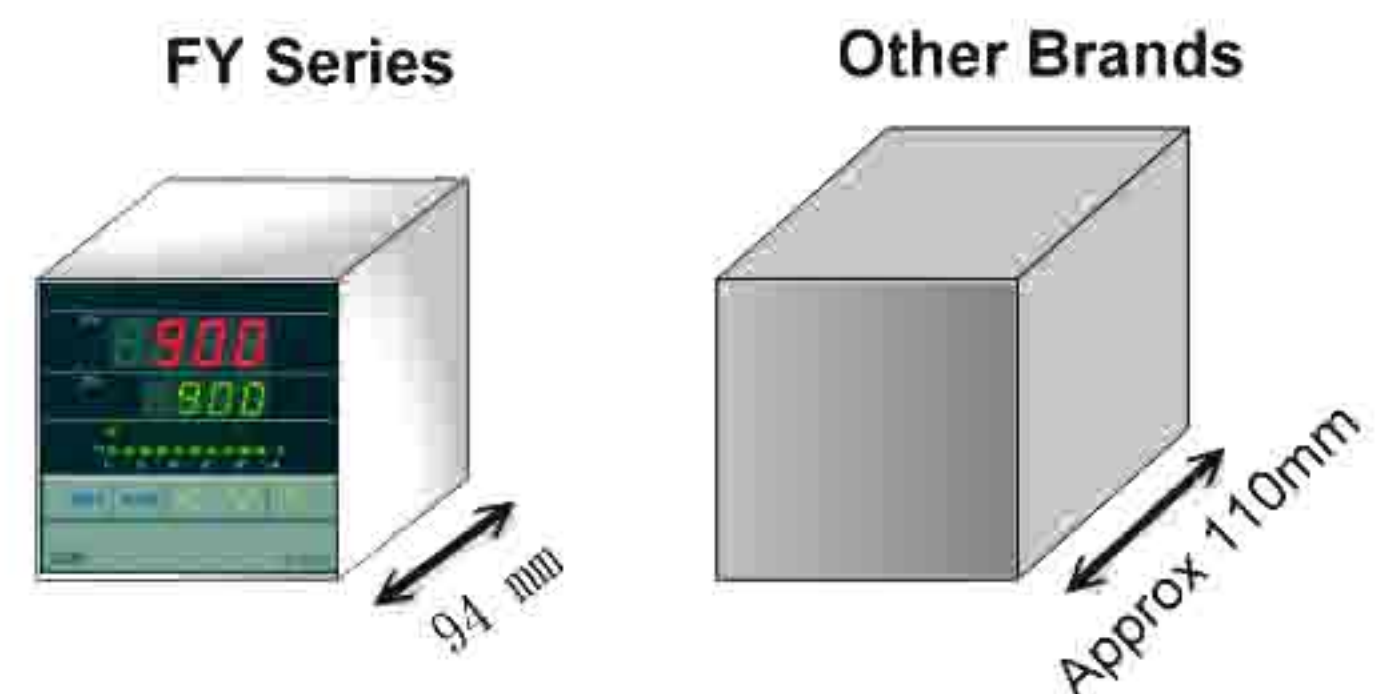

FY Series are shorter than other brands. But with more functions.

Alarm Function

Alarm Types

Maximun with 3 sets of alarm.

Alarm types list as below:

Deviation

Deviation High Alarm
Deviation Low Alarm
Deviation High/Low Alarm
Band Alarm

System

System Failed Alarm
System Normal Alarm

PV

PV High Alarm
PV Low Alarm

Program

Program Run Alarm
Program End Alarm
Segment End Alarm

Delay Time

Use this function can avoid alarm acts fequently or acts due to external disturbance.

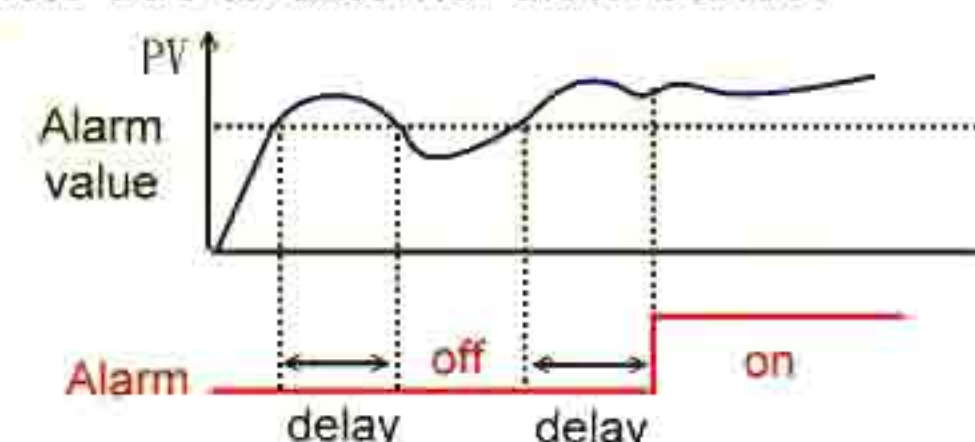

Hold Function

Use this function can avoid alarm acts at start-up. The alarm action is suppressed at start-up until PV enters the non-alarm range.

Parts Description

FY400

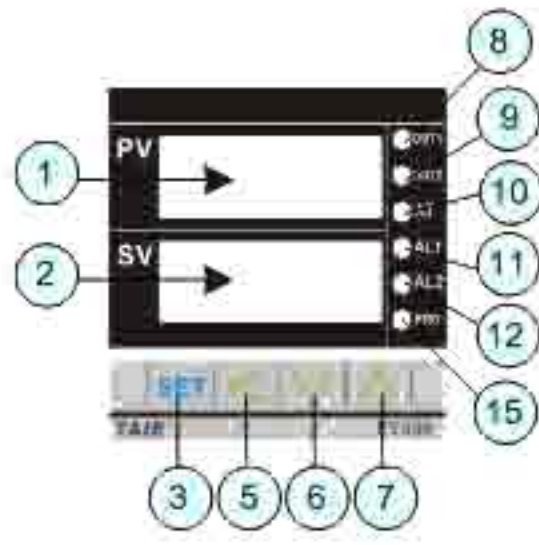

FY600

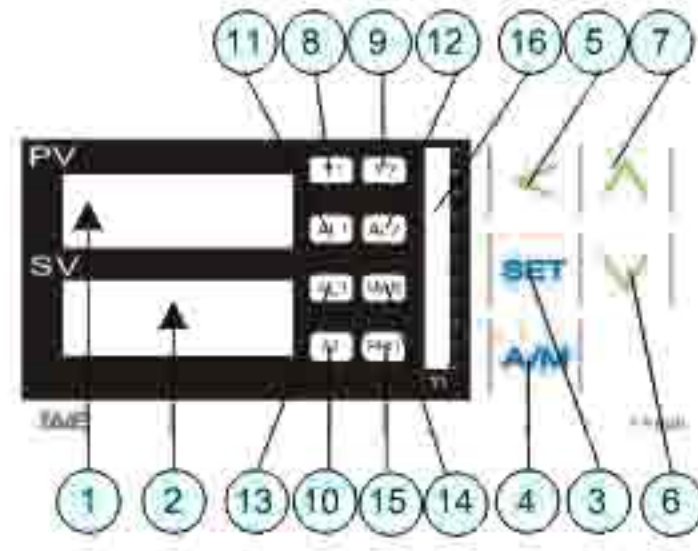

FY800

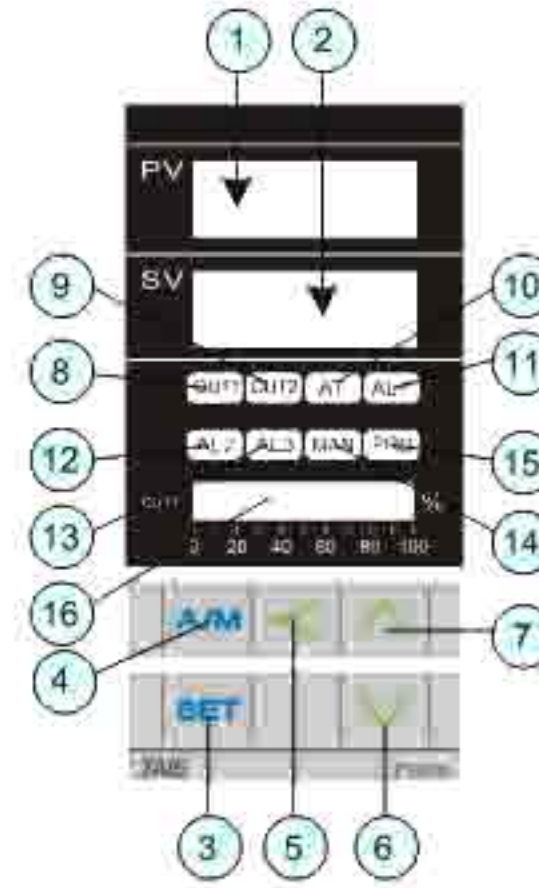

FY700/900

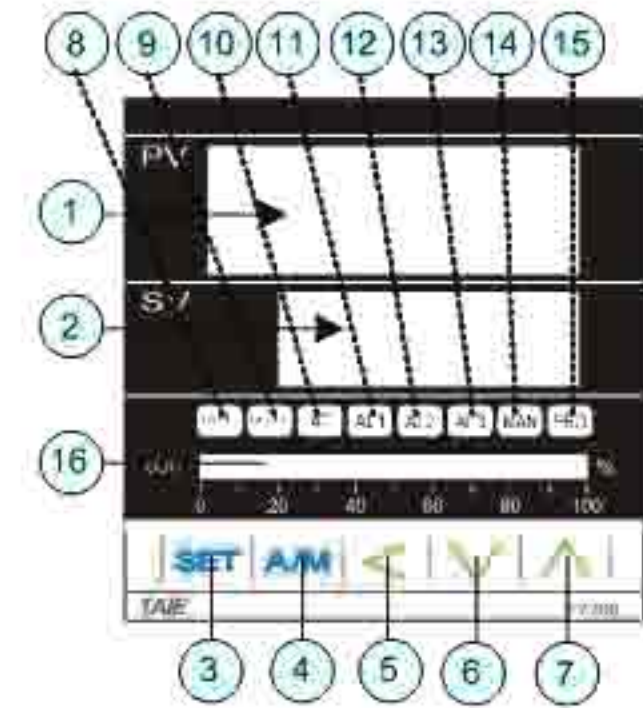

SYMBOL	NAME	FUNCTION
PV ①	Measured value (PV) display	Displays PV or various parameter symbols (Red)
SV ②	Setting value (SV) display	Displays SV or various parameter set values (Green)
SET ③	Set key	Used for parameter calling up and set value registration
A/M ④	Auto/Manual key	Switches between Auto(PID) output mode and Manual output
< ⑤	Shift key	Shift digits when settings are changed
∨ ⑥	Down key (*Program Hold)	Decrease numbers (*Only for programmable controller)
∧ ⑦	Up key (*Program Run)	Increase numbers (*Only for programmable controller)

SYMBOL	NAME	FUNCTION
OUT1 ⑧	OUT1 lamp	Lights when OUT1 is on (Green)
OUT2 ⑨	OUT2 lamp	Lights when OUT2 is on (Green)
AT ⑩	Autotuning lamp	Lights when Autotuning is activated (Orange)
AL1 ⑪	Alarm 1 lamp	Lights when Alarm 1 is activated (Red)
AL2 ⑫	Alarm 2 lamp	Lights when Alarm 2 is activated (Red)
AL3 ⑬	Alarm 3 lamp	Lights when Alarm 3 is activated (Red)
MAN ⑭	Manual output lamp	Lights when manual output is activated (Orange)
PRO ⑮	*Program Running lamp	*Flashes when program running (Only for programmable controller)
OUT1 % ⑯	Output% Bar-Graph display	Output% is displayed on 10-dot LEDs

External Dimension

Unit : mm

FY400			
FY600			
FY700			
FY800			
FY900			

Terminal Arrangement

FY Series

Digital PID Controller

FY400

FY700

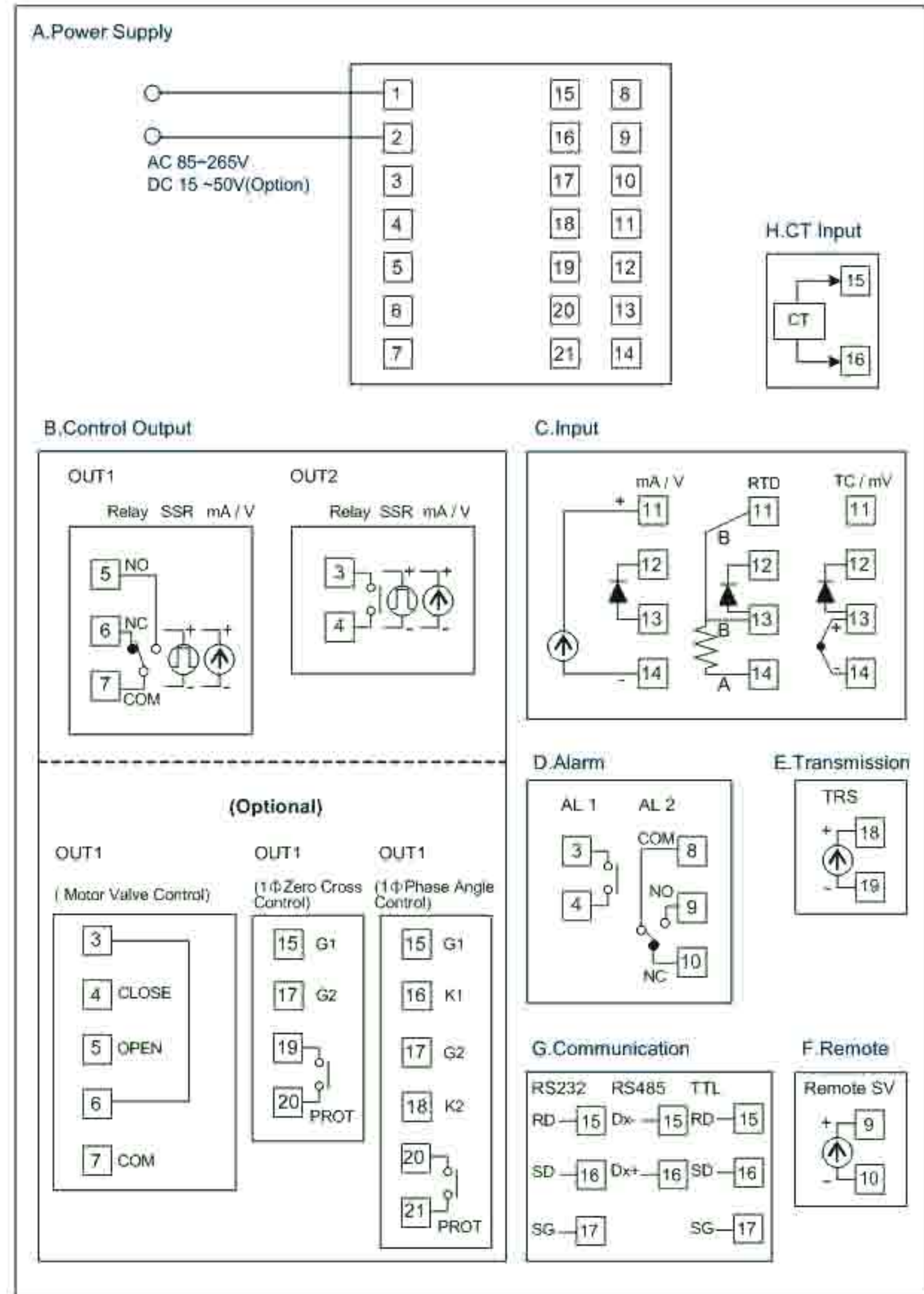
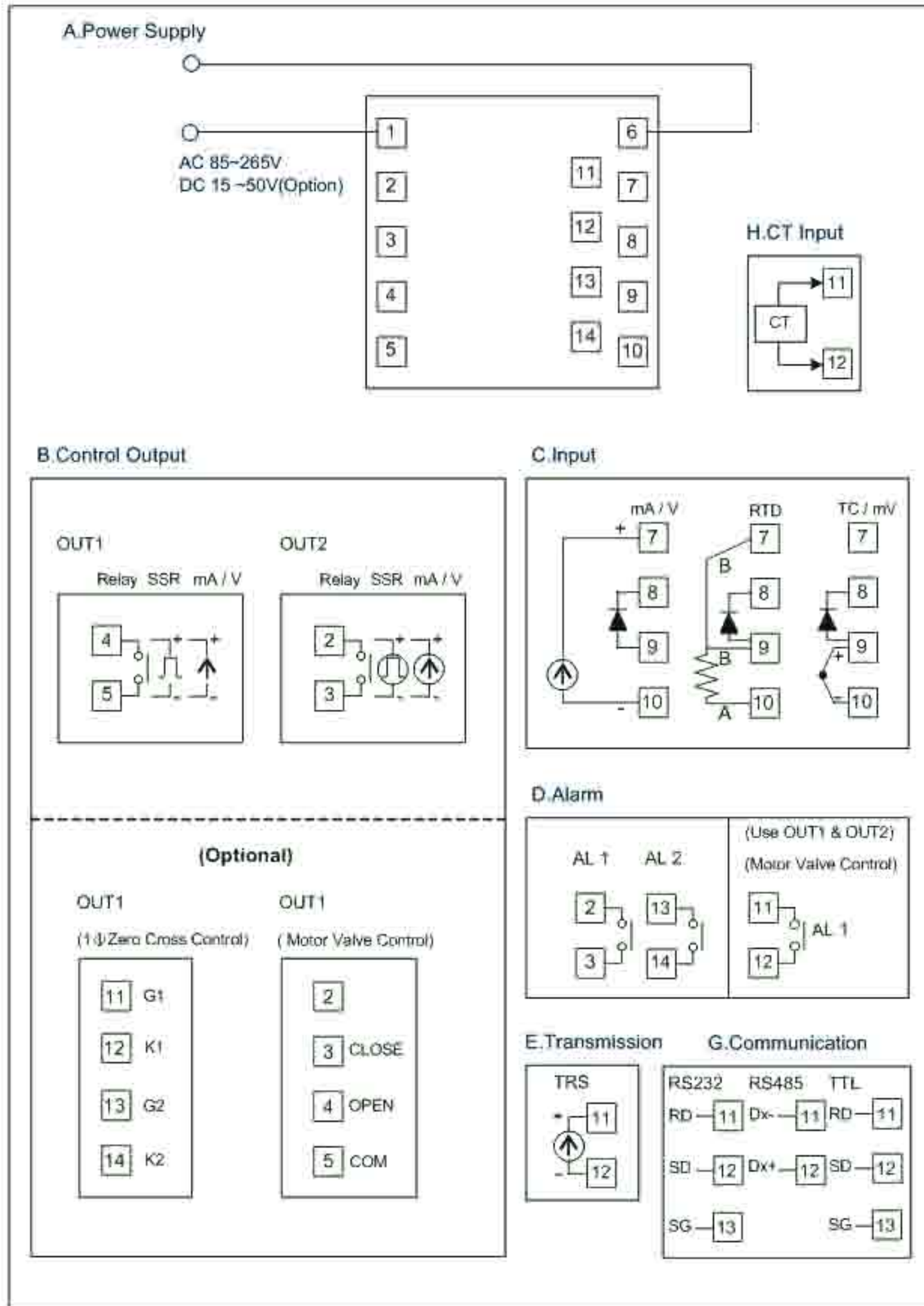

FY600/800

FY900

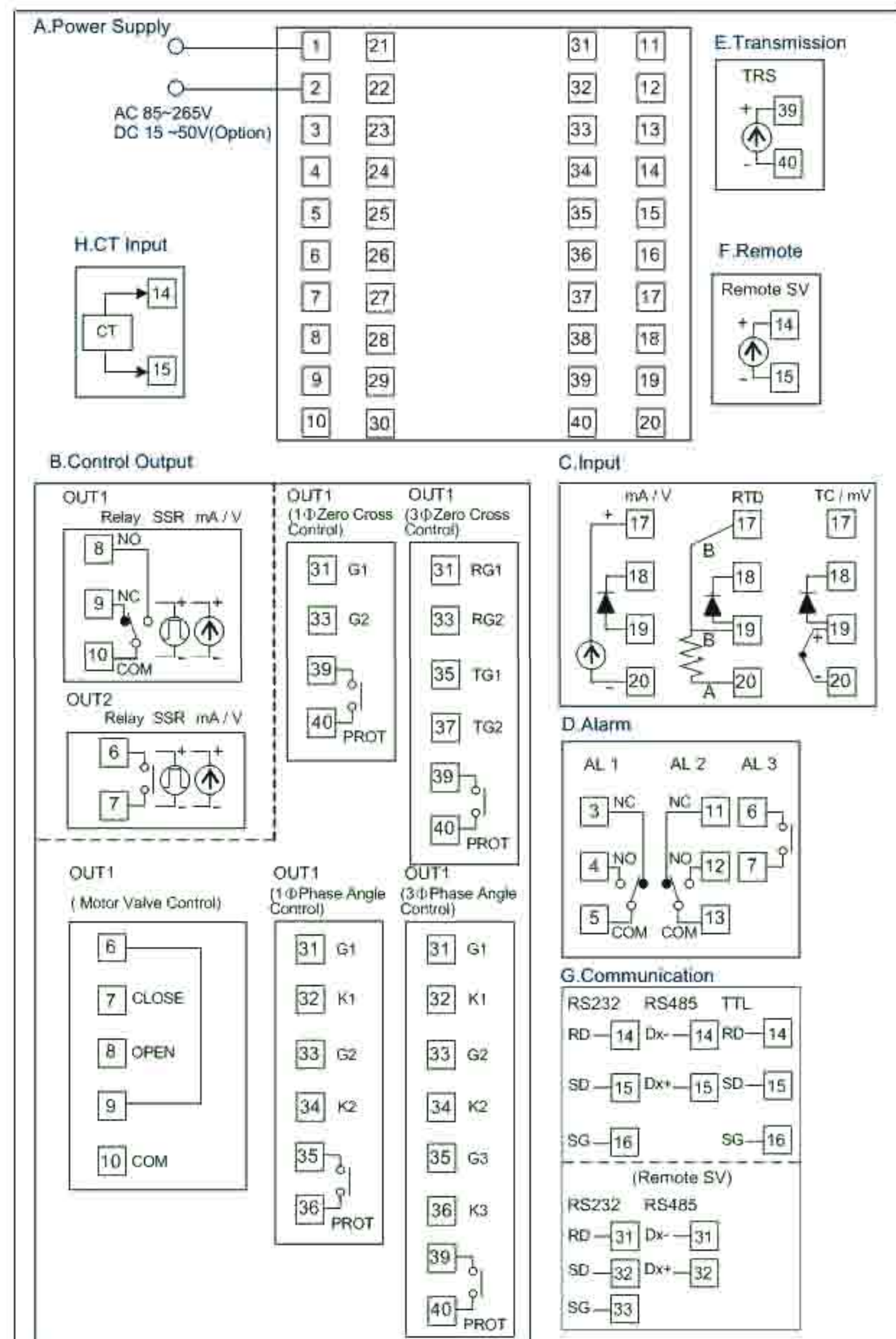
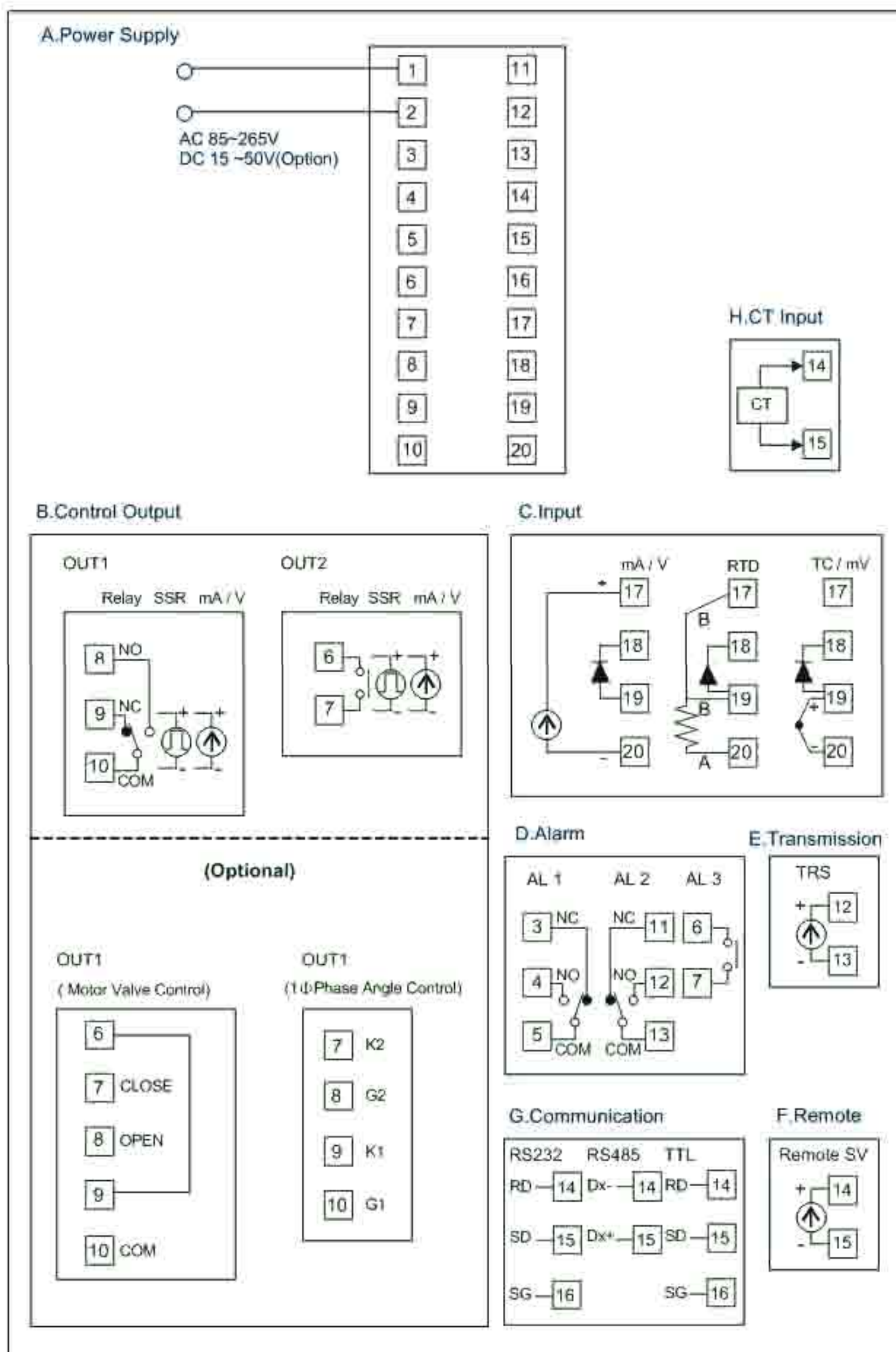

Standard Spec.

Model	FY400	FY600	FY700	FY800	FY900
Dimension	48X48mm	96X48mm	72X72mm	48X96mm	96X96mm
Supply voltage	AC 85~265V , DC24V (Optional)				
Frequency	50 / 60 HZ				
Power Consumption	approx 3VA	approx 4VA	approx 3VA	approx 4VA	approx 4VA
Memory	Non-volatile memory E ² PROM				
Input	Accuracy :0.2%FS , Sample time : 250ms				
TC	K , J , R , S , B , E , N , T , W5Re/W26Re , PL2 , U , L				
RTD	PT100 , JPT100 , JPT50				
mA dc	4~20mA , 0~20mA				
Voltage dc	0~1V , 0~5V , 0~10V , 1~5V , 2~10V -10~10mV , 0~10mV , 0~20mV , 0~50mV , 10~50mV				
DP Position	0000 , 000.0 , 00.00 , 0.000 (available for mA or Voltage dc input)				
Output 1	Main control output				
Relay	SPST type	SPDT type	SPDT type	SPDT type	SPDT type
	3A , 220V , electrical life : 100,000 times or more(under the rated load).				
Voltage Pulse	For SSR drive. ON:24V , OFF:0V , maximum load current:20mA.				
mA dc	4~20mA , 0~20mA .Maximum load resistance:560 Ω				
Voltage dc	0~5V , 0~10V , 1~5V , 2~10V. Maximum load current:20mA.				
Alarm 1	SPST type	SPDT type	SPST type	SPDT type	SPDT type
	3A , 220V , electrical life : 100,000 times or more(under the rated load).				
Control algorithms	PID , P , PI , PD , ON/OFF(P=0) , FUZZY				
PID range	P:0~200% , I:0~3600 Secs , D:0~900 Secs				
Isolation	Output terminals (control output , alarm ,transmission) and Input terminals are isolated separately.				
Isolated resistance	10M Ω or more between input terminals and case(ground) at DC 500V 10M Ω or more between output terminals and case(ground) at DC 500V				
Dielectric strength	1000V AC for 1 minute between input terminals and case(ground) 1500V AC for 1 minute between output terminals and case(ground)				
Operating temperature	0~50°C				
Humidity range	20~90% RH				
Weight	FY400 approx 150g ,FY600/700/800 approx 225g , FY900 approx 300g.				
Display Height	PV:7mm SV:7mm	PV:7mm SV:7mm	PV:14mm SV:10mm	PV:7mm SV:7mm	PV:14mm SV:10mm

Optional Spec.

Model	FY400	FY600	FY700	FY800	FY900
RAMP/SOAK Program	2 Patterns with 8 segments each . The 2 patterns can be linked together as 16 segments use.				
Output 2	For heating and cooling control use				
Relay	SPST type	SPST type	SPST type	SPST type	SPST type
Voltage Pulse	For SSR drive. ON:20V , OFF:0V , maximum load current:20mA.				
mA dc	4~20mA , 0~20mA .Maximum load resistance:560 Ω				
Voltage dc	0~5V , 0~10V , 1~5V , 2~10V. Maximum load current:20mA.				
Alarm 2	SPST type	SPDT type	SPDT type	SPDT type	SPDT type
Alarm 3	X	SPST type	SPST type	SPST type	SPST type
Heater Break Alarm (HBA)	Display Range of Heater Current : 0.0~99.9 A , Accuracy : 1%FS Included CT : SC_80_T (5.8mm dia , 0.0~80.0A) or SC_100_T(12mm dia , 0.0~99.9A) Alarm Relay : AL1				
Transmission	Available for PV or SV transmission				
mA dc	4~20mA , 0~20mA. Maximum load resistance:560 Ω				
Voltage dc	0~5V,0~10V,1~5V,2~10V. Maximum load current:20mA.				
Remote SV Input	4~20mA , 0~20mA , 0~5V , 0~10V , 1~5V , 2~10V are available Protocol : MODBUS RTU , MODBUS ASCII , TAIE Interface : RS232 , RS485 , TTL				
Communication	Baudrate : 38400 , 19200 , 9600 , 4800 , 2400 bps. Data bits : 8 , Start bit : 1 , Stop bit : 1 or 2 , Odd or Even parity				
WaterProof/DustProof	IP65				

Order Information

FY Series

Digital PID Controller

Model & Suffix codes

Model	Output1	Output2	Alarm	TRS	Remote SV	Communication	Input Type	Power	Water/Dust Proof
FY400	— 1	0	1	0	0	0	— 02	— A	N
FY400	48x48mm	0 None	0 None	0 None	0 None	0 None	See Input Codes	A AC 85~265V	N None
FY600	96x48mm	1 Relay	1 Relay	1 1 Set	1 4~20mA	1 4~20mA		D DC24V	W IP65
FY700	72x72mm	2 Voltage Pulse (SSR Drive)	2 Voltage Pulse (SSR Drive)	2 2 Sets	2 0~20mA	2 0~20mA	1 RS232		
FY800	48x96mm	3 4~20mA	3 4~20mA	3 3 Sets	A 0~5V	A 0~5V	2 RS485		
FY900	96x96mm	4 0~20mA	4 0~20mA		B 0~10V	B 0~10V	3 TTL		
(STANDARD)					C 1~5V	C 1~5V	A RS232_MODBUS		
					D 2~10V	D 2~10V	B RS485_MODBUS		
PFY400	48x48mm	A 0~5V	A 0~5V						
PFY600	96x48mm	B 0~10V	B 0~10V						
PFY700	72x72mm	C 1~5V	C 1~5V						
PFY800	48x96mm	D 2~10V	D 2~10V						
PFY900	96x96mm								
(RAMP/SOAK Programmable)									
		5 1φSCR zero cross control							
		6 3φSCR zero cross control							
		7 Motor valve control							
		8 1φSCR phase angle control							
		9 3φSCR phase angle control							



* Block means optional functions with additional charge
 * HBA : Heater Break Alarm (HBA must use AL1 as alarm relay)

Combination of options and models

○ Available ✗ Not available

Options	RAMP/SOAK PROGRAM	Output 1	Output2	Alarm2	Alarm3	HBA	TRS	Remote SV	Communication	Power DC 24V
Model	PROGRAM	1φSCR_Z	3φSCR_Z	Motor valve control	1φSCR_P	3φSCR_P				
FY400	○	○	✗	○	✗	✗	○	○	○	○
FY600	○	✗	✗	○	○	✗	○	○	○	○
FY700	○	○	✗	○	○	✗	○	○	○	○
FY800	○	✗	✗	○	○	✗	○	○	○	○
FY900	○	○	○	○	○	○	○	○	○	○

*Remote SV function is not available, if HBA Function has been specified.

Input type table

	TC			TC			TC			LINEAR				
	TYPE	CODE	RANGE	TYPE	CODE	RANGE	TYPE	CODE	RANGE	TYPE	CODE	RANGE		
TC	K	K1	01	0.0~200.0°C (392.0°F)	K2	02	0.0~400.0°C (752.0°F)	K3	03	0~600°C (1112°F)	LINEAR	AN1	61	-10 ~ 10mV
		K4	04	0~800°C (1472°F)	K5	05	0~1000°C (1832°F)	K6	06	0~1200°C (2192°F)		62	-2 ~ 2V	
	J	J1	07	0.0~200.0°C (392.0°F)	J2	08	0.0~400.0°C (752.0°F)	J3	09	0~600°C (1112°F)		63	-5 ~ 5V	
		J4	10	0~800°C (1472°F)	J5	11	0~1000°C (1832°F)	J6	12	0~1200°C (2192°F)		64	-10 ~ 10V	
	R	R1	13	0~1600°C (2912°F)	R2	14	0~1769°C (3216°F)	LINEAR	AN2	71		0 ~ 10mV		
	S	S1	15	0~1600°C (2912°F)	S2	16	0~1769°C (3216°F)		AN3	76		0 ~ 20mV		
	B	B1	17	0~1820°C (3308°F)	E	E1	18		0~800°C (1472°F)	AN4		81	0 ~ 50mV	
	E	E1	18	0~800°C (1472°F)		E2	19		0~900°C (1652°F)	82		0 ~ 20mA	-1999 ~ 9999	
	N	N1	20	0~1200°C (2192°F)	N2	21	0~1300°C (2372°F)		83	0 ~ 1V		-199.9 ~ 999.9		
	T	T1	22	-199.9~400.0°C (752.0°F)	T2	23	-199.9~200.0°C (392.0°F)		T3	24		0.0~350.0°C (662.0°F)	84	0 ~ 5V
W	W1	25	0~2000°C (3632°F)	W2	26	0~2320°C (4208°F)	LINEAR		85	0 ~ 10V	-1.999 ~ 9.999			
PLII	PL1	27	0~1300°C (2372°F)	PL2	28	0~1390°C (2534°F)			86	0 ~ 5K ohm	-1.999 ~ 9.999			
U	U1	29	-199.9~600.0°C (999.9°F)	U2	30	-199.9~200.0°C (392.0°F)			U3	31	0.0~400.0°C (752.0°F)	87	0 ~ 2V	
L	L1	32	0~400°C (752°F)	L2	33	0~800°C (1472°F)			LINEAR	AN5	91	10 ~ 50mV		
JPT	JP1	41	-199.9~600.0°C (999.9°F)	JP2	42	-199.9~400.0°C (752.0°F)		JP3		43	-199.9~200.0°C (392.0°F)	92	4 ~ 20mA	
100	JP4	44	0~200°C (392°F)	JP5	45	0~400°C (752°F)		JP6		46	0~600°C (1112°F)	93	1 ~ 5V	
PT	DP1	47	-199.9~600.0°C (999.9°F)	DP2	48	-199.9~400.0°C (752.0°F)		DP3		49	-199.9~200.0°C (392.0°F)	94	2 ~ 10V	
100	DP4	50	0~200°C (392°F)	DP5	51	0~400°C (752°F)		DP6		52	0~600°C (1112°F)			
JPT	JP.1	53	-199.9~600.0°C (999.9°F)	JP.2	54	-199.9~400.0°C (752.0°F)		JP.3		55	-199.9~200.0°C (392.0°F)			
50	JP.4	56	0~200°C (392°F)	JP.5	57	0~400°C (752°F)		JP.6		58	0~600°C (1112°F)			