

FY Series Digital PID Controller Operation Manual

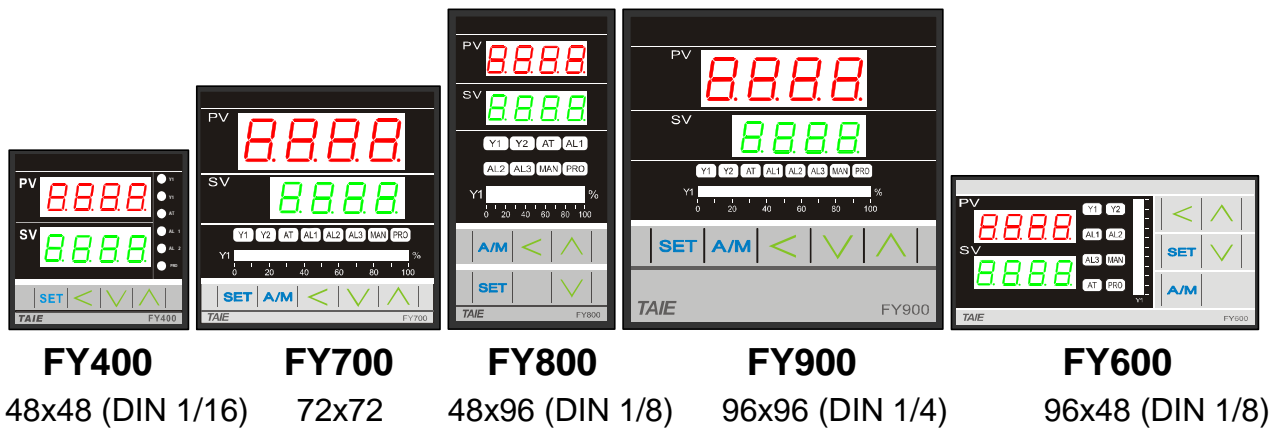

2005.02

CONTENT

1	Notice before start- up	Page 3
2	Specifications	Page 4
3	Terminal arrangement	
3.1	FY400 Terminals	Page 6
3.2	FY600 Terminals	Page 7
3.3	FY700 Terminals	Page 8
3.4	FY800 Terminals	Page 9
3.5	FY900 Terminals	Page 10
4	External dimension and panel cutout	Page 11
5	Parts description.....	Page 12
6	Operations	
6.1	Power On	Page 13
6.2	Change the Set Value (SV)	Page 13
6.3	Change The Alarm Value.....	Page 13
6.4	Autotuning (AT)	Page 14
6.5	Programmable RAMP / SOAK	Page 15
7	Operation levels	
7.1	Levels diagram	Page 16
7.2	Lock function	Page 16
8	Parameters	
8.1	Level 1 (User Level)	Page 17
8.2	Level 2 (PID Level)	
8.2.1	Level 2 parameters display / hiding condition.....	Page 18
8.2.2	Description of parameters.....	Page 19
8.3	Level 3 (Input Level)	Page 20
8.4	Level 4 (SET Level)	
8.4.1	How to hide parameters (Use SET1~SET7)	Page 22
8.4.2	Special functions (Use SET8 / SET9 / SET0).....	Page 23
8.4.3	Remote SV type selection.....	Page 24
8.4.4	Output mode selection (Use OUTY)	Page 24
8.5	Program Level	
8.5.1	Description of parameters	Page 25
8.5.2	Description of operation.....	Page 26
9	Input type table	Page 27
10	Alarm	
10.1	Alarm time.....	Page 29
10.2	SETA	Page 29
10.3	Alarm mode	Page 30

11	Error codes	Page 31
12	Modify input type: TC, RTD	Page 32
13	Modify input type: Linear Input (mA ,V)	
13.1	Hardware	Page 33
13.2	Calibration	Page 34
14	Modify output type: Relay, SSR, 4~20mA	Page 35
15	Modify output mode: OUT1/ALARM, OUT1/OUT2	Page 35
16	Applications	
16.1	RAMP & SOAK	Page 36
16.2	TTL Communication : SV output and RATE function.....	Page 37
16.3	1 Phase angle control (By SCR module)	Page 38
16.4	1 Phase angle control (By TRIAC)	Page 39
16.5	3 Phase angle control (By DIODE/SCR module).....	Page 40
16.6	1 Zero crossing control (By SCR Module)	Page 41
16.7	1 Zero crossing control (By TRIAC)	Page 42
16.8	3 Zero crossing control (By SCR module)	Page 43
16.9	3 Zero crossing control (By TRIAC)	Page 44
16.10	3 wires proportional motor valve control	Page 45
16.11	Communication	
16.11.1	Protocol	Page 46
16.11.2	Wiring diagram	Page 49

1. Notice before start-up

FY series controller has got the CE approvals as below:

LDV : D/N EN61010-1

EMC : EN 55 022 1994 /A1 : 1995/ A2 : 1997

EN 61 000-3-2 : 1995 / -3-3 : 1995

EN 61 000-4-2 : 1995 / -4-3 : 1996 / -4-5 : 1995 / -4-6

1996 / -4-8 : 1993 / -4-11 : 1996/ EN 50 204 : 1995

Please confirm the specification of controller is to totally with your requirement before using it, also read this manual in detail.

Danger

1. Danger! Electric Shock!

DON'T touch AC power wiring terminals when controller has been powered!

Keep the power off until all of the wirings are completed!

Warning

1. Please confirm the AC power wiring to controller is correct, otherwise it would be caused aggravated damage on controller. (FY400 connecting with Pin 1 and 6, FY600/700/800/900 with Pin 1 and 2).
2. Be sure to use the rated power supply (AC85~265V or DC24V), otherwise it would be caused aggravated damage on controller.
3. Please confirm wires are connected with correct terminal (Input, Output).
4. Use M3 screw-compatible crimp-on terminals with an insulation sleeve, as shown below

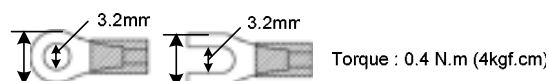

5. Avoid installing controller in following spaces:
 - I. A place where the ambient temperature may reach beyond the range from 0 to 50
 - II. A place where the ambient humidity may reach beyond the range from 50 to 85% RH.
 - III. A place where the controller likely to come into contact with water, oil, chemicals, steam and vapor.
 - IV. A place where the controller is subject to interface with static electricity, magnetism and noise.
6. For thermocouple (TC) input, use shield compensating lead wire.
7. For RTD input, use shield wires which have low resistance and no resistance difference between the 3 wires.

1. Specifications

● Standard spec.

Model		FY400	FY600	FY700	FY800	FY900
Dimension		48X48mm	96X48mm	72X72mm	48X96mm	96X96mm
Supply voltage		AC 85~265V , DC 15~50V (Option)				
Frequency		50 / 60 HZ				
Power consumption		approx 3VA	approx 4VA	approx 3VA	approx 4VA	approx 4VA
Input	TC	K,J,R,S,B,E,N,T,W,PL2,U,L				
	RTD	DPT100,JPT100,JPT50				
	mA dc	4~20mA ,0~20mA				
	mV / V dc	0~1V,0~5V,0~10V,1~5V,2~10V -10~10mV,0~10mV,0~20mV,0~50mV,10~50mV				
	Decimal point position	0000 , 000.0 , 00.00 , 0.000 Available for linear input (mA / mV / V)				
Output 1	Relay	SPST type	SPDT type	SPDT type	SPDT type	SPDT type
		3A , 220V , electrical life:100,000 times or more (under rated load)				
	Voltage pulse	For SSR drive. ON : 24V , OFF : 0V , max load current : 20mA				
	mA dc	4~20mA, 0~20mA. Maximum load resistance:560 Ω				
	Voltage dc	0~5V , 0~10V , 1~5V , 2~10V . Max load current:20mA				
Alarm 1		3A , 220V , electrical life:100,000 times or more (under rated load)				
Control algorithm		PID , PI , PD , P , ON / OFF(P=0) , FUZZY。				
Accuracy		0.2% + 1digit				
Sample time		250 ms				
PID range		P: 0.0 ~ 200.0 % , I: 0~3600s , D: 0~900s				
Isolation		Output terminals(control output , alarm , transmission) and input terminals are isolated separately				
Isolated resistance		10MΩ or more between input and case (ground) at DC 500 V 10MΩ or more between output and case (ground) at DC 500 V				
Dielectric strength		1000V AC for 1 minute between input terminal and case (ground) 1500V AC for 1 minute between output terminal and case (ground)				
Operating temperature		0~50				
Humidity range		50~85%RH				
Weight		150g	225g	225g	225g	300g
Display Height		PV:7mm SV:7mm	PV:7mm SV:7mm	PV:14mm SV:10mm	PV:7mm SV:7mm	PV:14mm SV:10mm

● **Optional Spec.**

Model	FY400	FY600	FY700	FY800	FY900
Output 2	Available for all models.				
	For heating and cooling control use. Relay , SSR , 4~20mA , 0~20mA , 0~5V , 0~10V , 1~5V , 2~10V				
Alarm 2	Available for all models.				
	SPST type	SPDT type	SPST type	SPDT type	SPDT type
	3A , 220V , electrical life:100,000 times or more (under rated load)				
Alarm 3	Not available	Available	Not available	Available	Available
		SPST type		SPST type	SPST type
	3A , 220V , electrical life:100,000 times or more (under rated load)				
Transmission	Available for all models.				
	4~20mA , 0~20mA , 0~1V , 0~5V , 0~10V , 1~5V , 2~10V				
Remote SV	Not available	Available	Available	Available	Available
	4~20mA , 0~20mA , 0~1V , 0~5V , 0~10V , 1~5V , 2~10V				
Communication	Available for all models.				
	RS232 , RS485 , TTL				
	Baud rate: 9600,4800,2400,1200,300,110 bps.				
	Start bit : 1 bit , Stop bit : 1 bit , Odd parity.				
Waterproof /Dust proof	Available for all models.				
	IP66 (NEMA4)				

● **Special control output**

Model	FY400	FY600	FY700	FY800	FY900
1φ zero crossing control(1φSSR)	Available	Not available	Available	Not available	Available
3φ zero crossing control(3φSSR)	Not available				Available
Motor valve control	Available				
1φ phase angle control(1φSCR)	Not available	Available			
3φ phase angle control(3φSCR)	Not available				Available

● **Programmable RAMP/SOAK**

Model	PFY400	PFY600	PFY700	PFY800	PFY900
Programmable RAMP/SOAK	2 patterns with 8 segments each. The 2 patterns can be linked together as 16 segments use.				

3. Terminal arrangement

3.1 FY400 Terminals (48mm x 48mm , DIN 1/16)

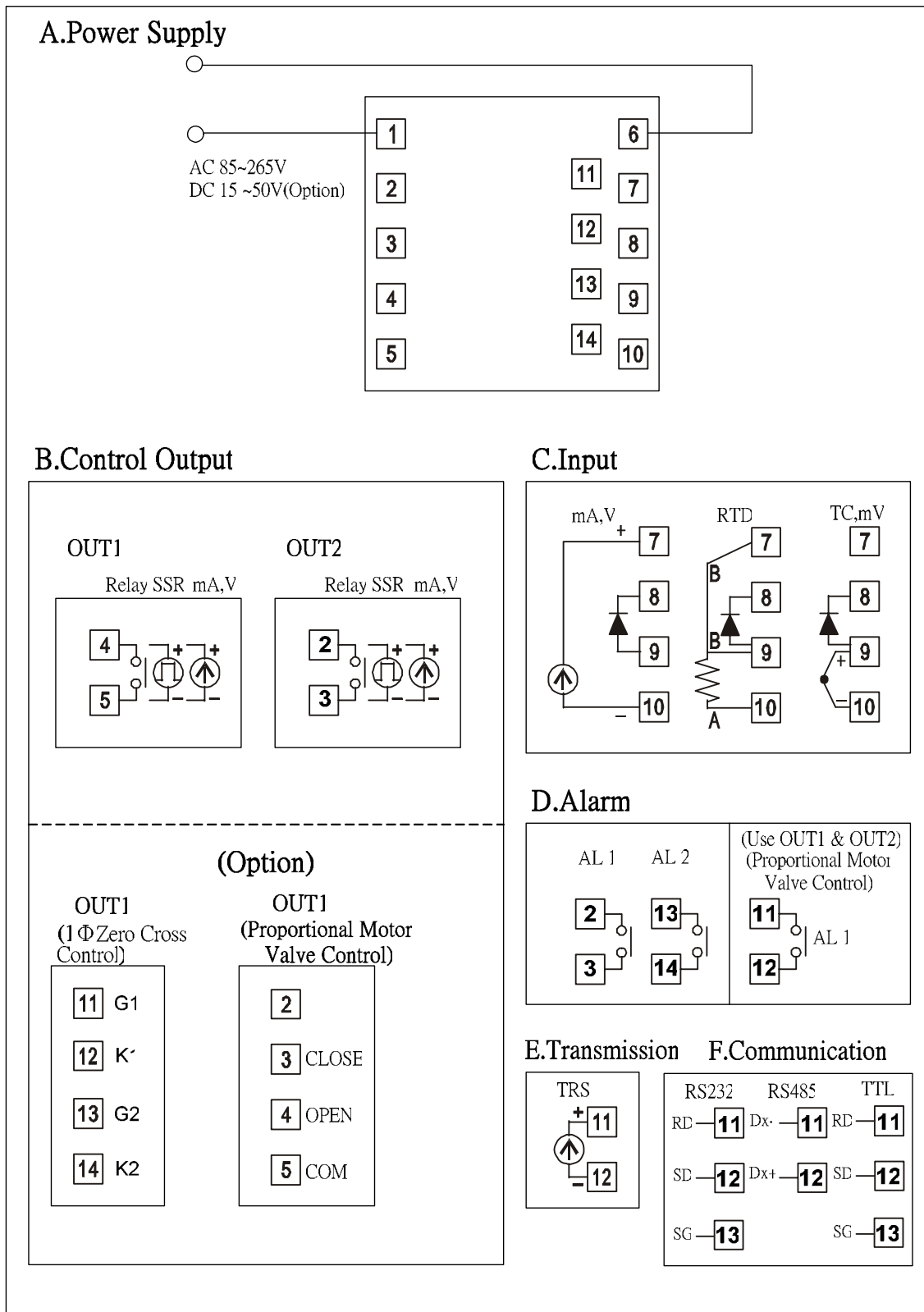

3.2 FY600 Terminals (96mm x 48mm , DIN 1/8)

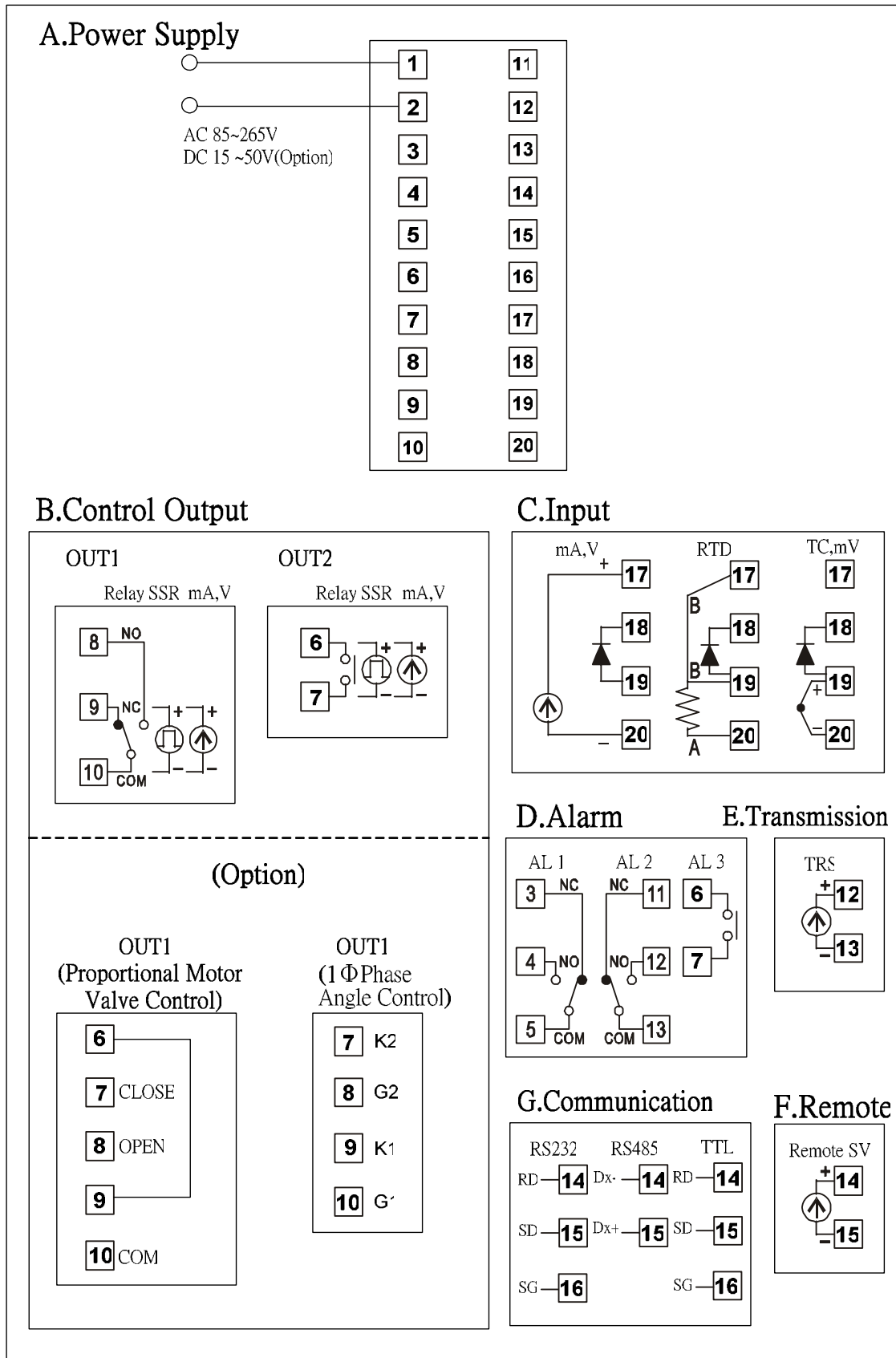

3.3 FY700 Terminals (72mm x 72mm)

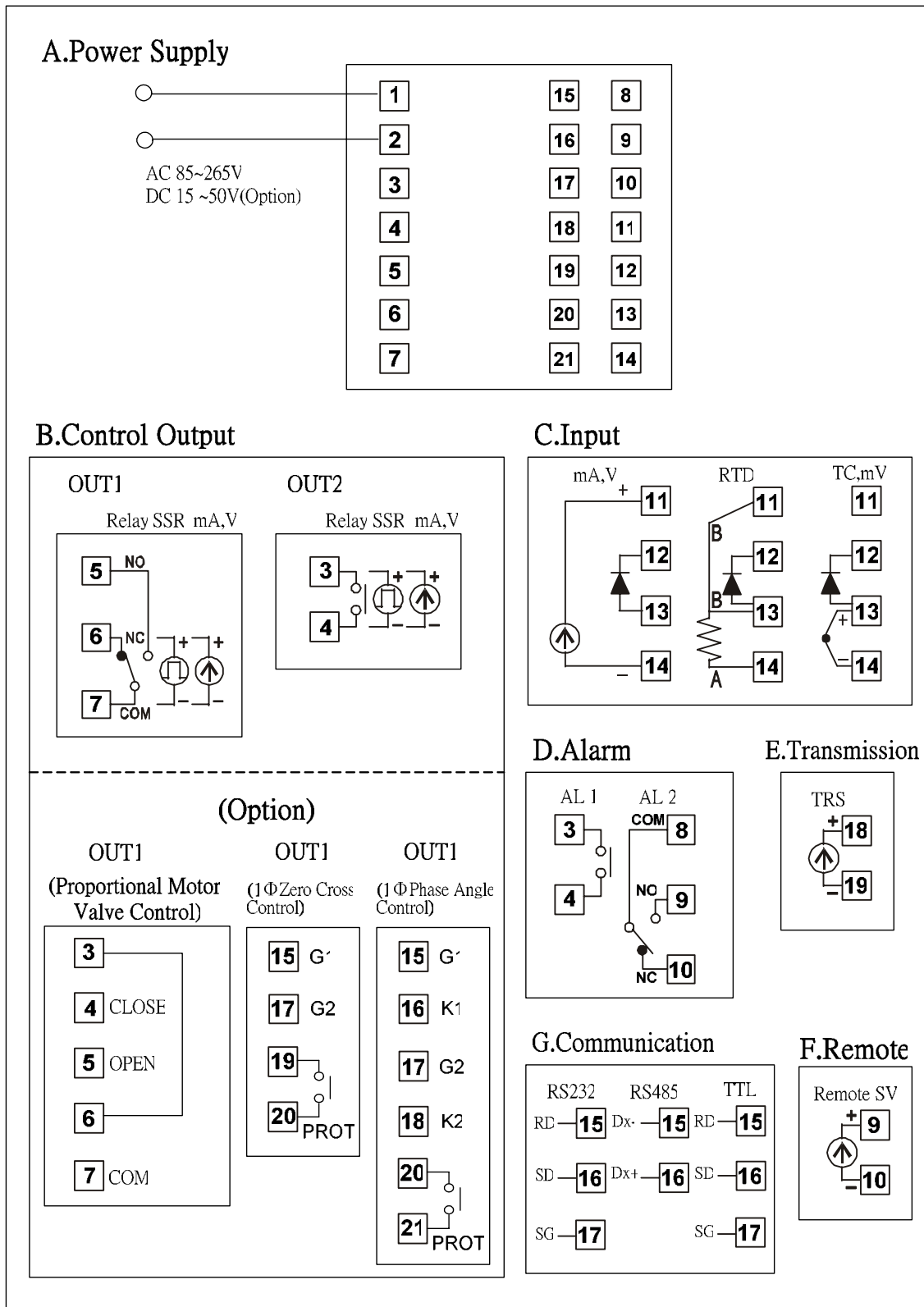

3.4 FY800 Terminals (48mm x 96mm , DIN 1/8)

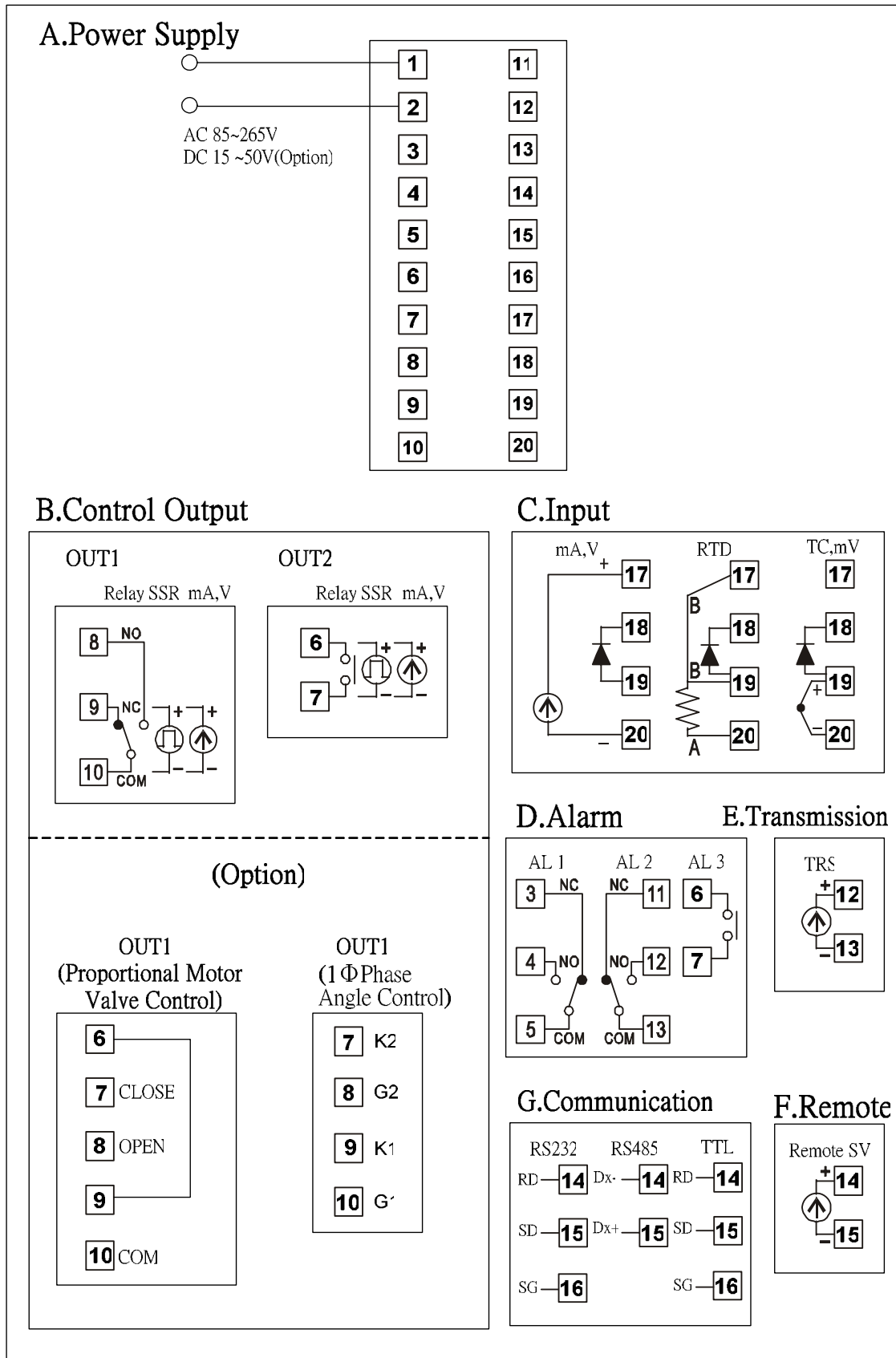

3.5 FY900 Terminals (96mm x 96mm , DIN 1/4)

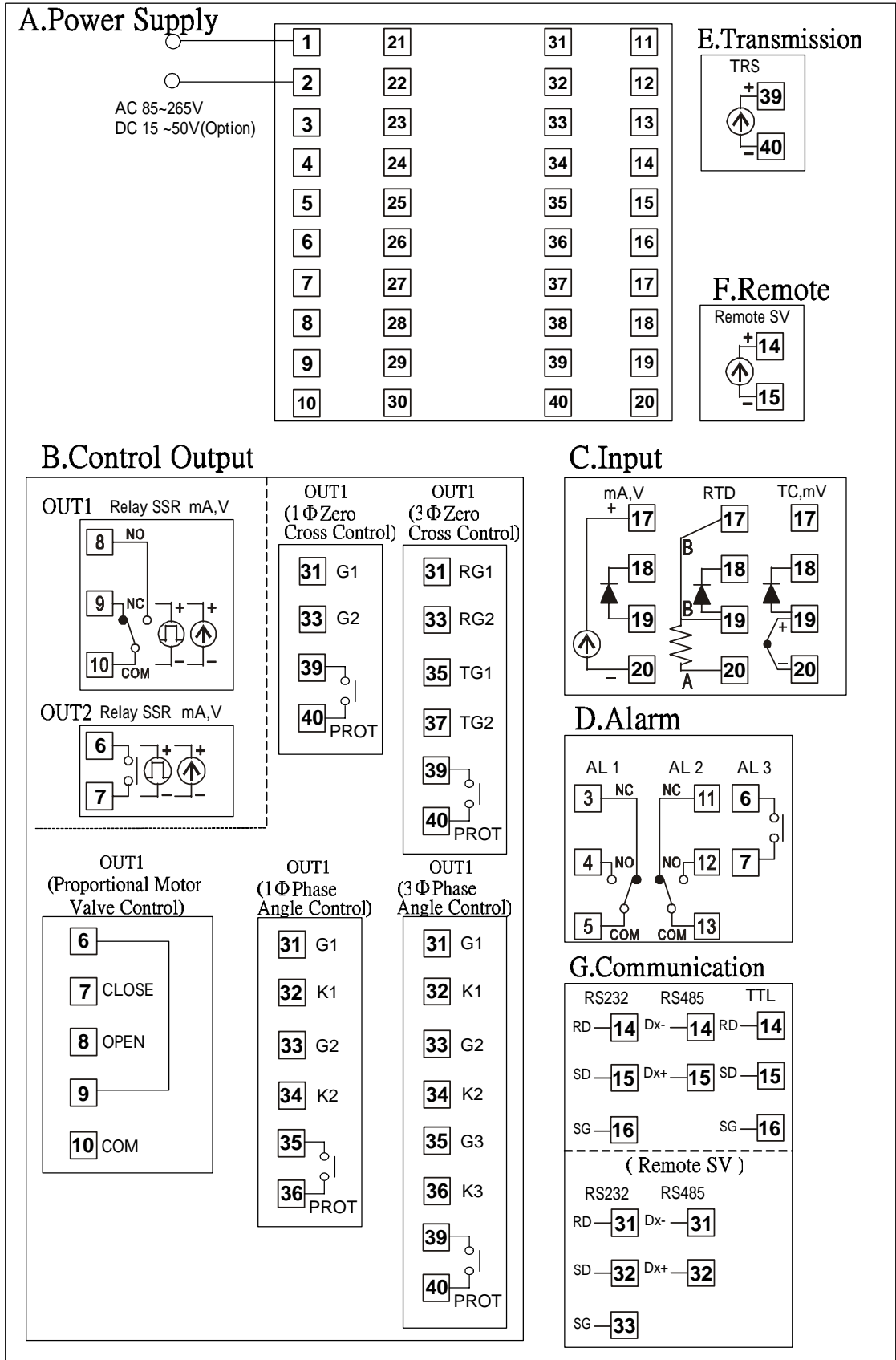

4. External dimension and panel cutout Unit : mm

FY400

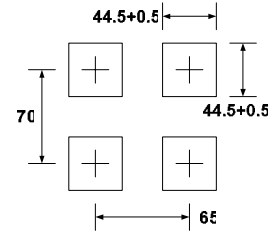
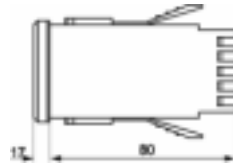
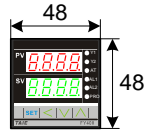

FY600

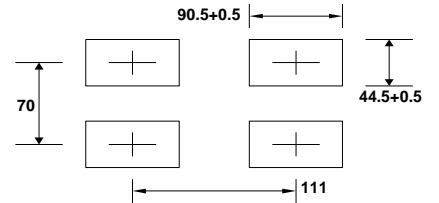
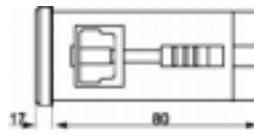
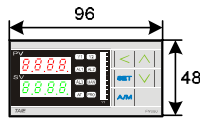

FY700

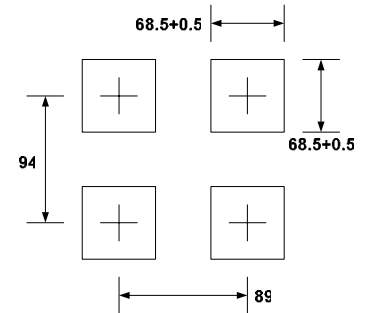
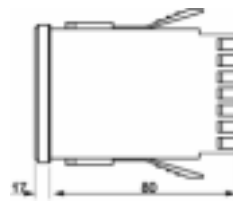
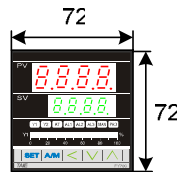

FY800

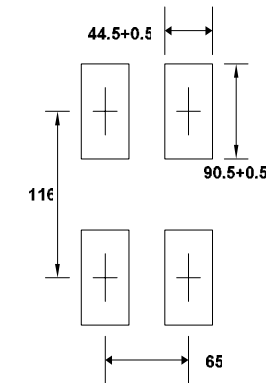
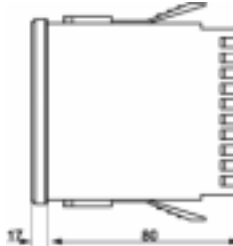
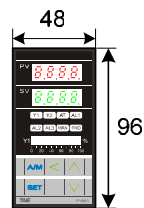

FY900

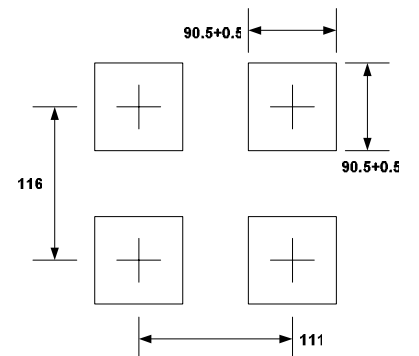
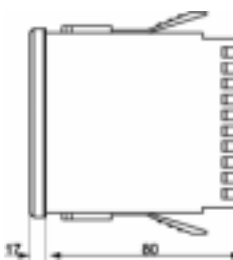
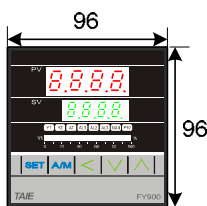

5. Parts description

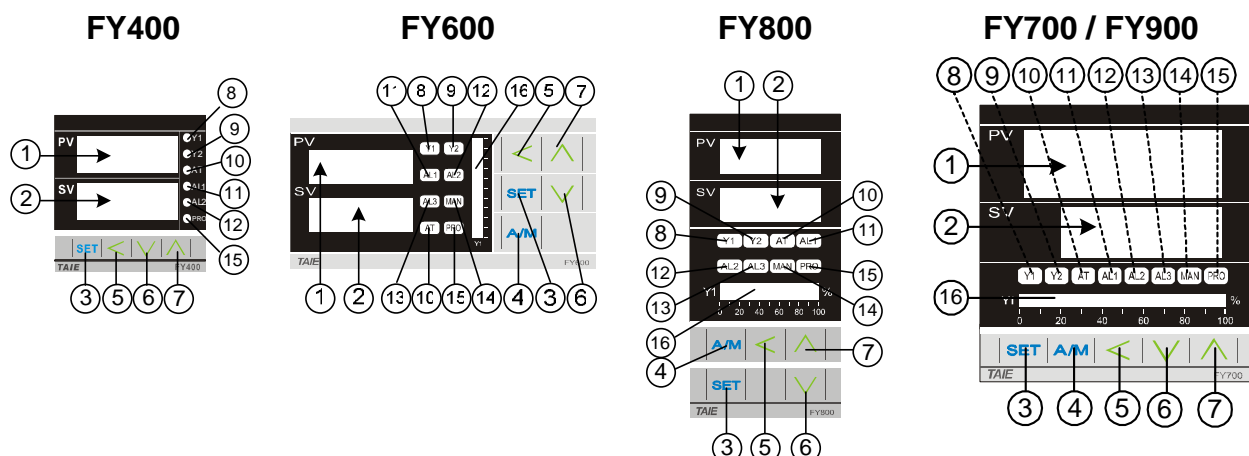

SYMBOL	NAME		FUNCTION
PV	①	Measured value (PV) display	Displays PV or various parameter symbols (Red)
SV	②	Set value (SV) display	Displays SV or various parameter set values (Green)
SET	③	Set key	Used for parameter calling up and set value registration
A/M	④	Auto/Manual key	Switches between Auto(PID) output mode and Manual output mode.
<	⑤	Shift key	Shift digits when settings are changed
∨	⑥	Down key <i>*Program hold</i>	Decrease numbers (-1000,-100,-10,-1) <i>* Program hold Programmable controller</i>
∧	⑦	Up key <i>*Program run</i>	Decrease numbers (+1000,+100,+10,+1) <i>* Program run Programmable controller</i>
OUT1	⑧	OUT1 lamp	Lights when OUT1 is activated (Green)
OUT2	⑨	OUT2 lamp	Lights when OUT2 is activated (Green).
AT	⑩	Auto tuning lamp	Lights when Auto tuning is activated (Orange)
AL1	⑪	Alarm 1 lamp	Lights when Alarm 1 is activated (Red)
AL2	⑫	Alarm 2 lamp	Lights when Alarm 2 is activated (Red)
AL3	⑬	Alarm 3 lamp	Lights when Alarm 3 is activated (Red)
MAN	⑭	Manual output lamp	Lights when manual output is activated (Orange)
PRO	⑮	<i>*Program running lamp</i>	<i>*Flashes when program is running Programmable controller .</i>
OUT1%	⑯	OUT% bar-graph display	Output% is displayed on 10-dot LED.

6. Operations

6.1 Power On

Controller will display as following::

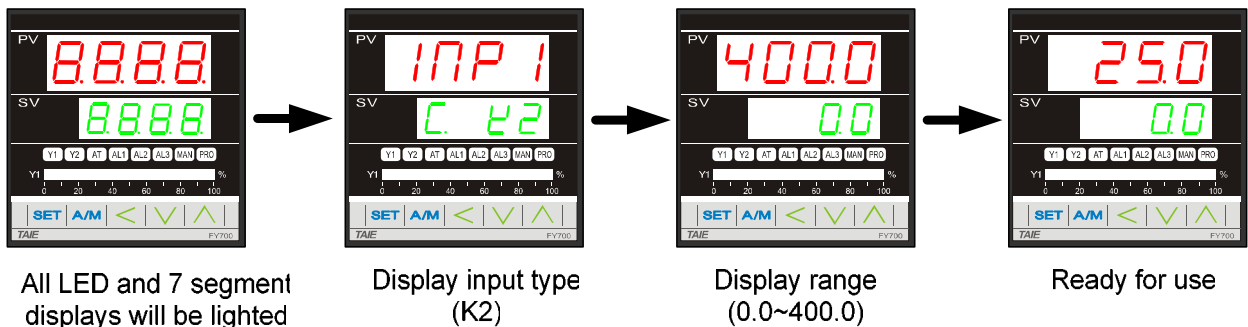

6.2 Change the Set Value (SV)

Change SV from 0.0 to 100.0

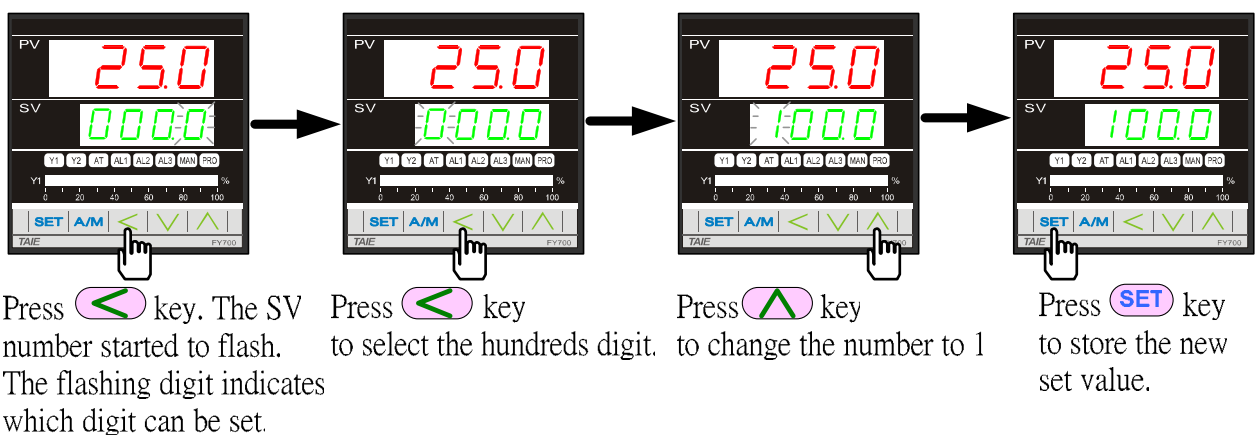

6.3 Change the Alarm Value

Change AL1 value to "5.0" (AL1 active, if PV exceeds SV over 5.0)

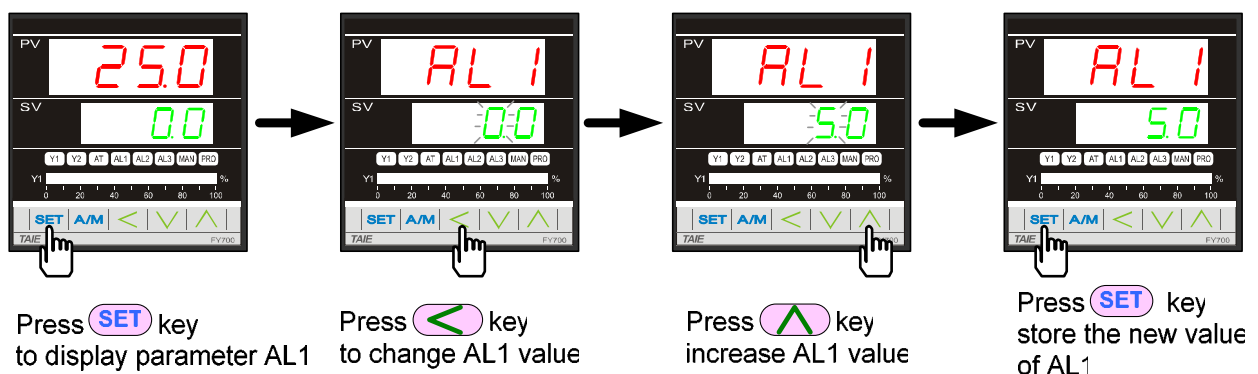

* The are total 16 alarm mode types, please referred with "alarm mode" in page 30

* To change alarm mode, press + key 5 seconds to enter Level 3 (Input Level) and then change ALD1/ALD2/ALD3 value.

6.4 Autotuning (AT)

Use AT function to automatically calculate and set the optimize PID value for your system.

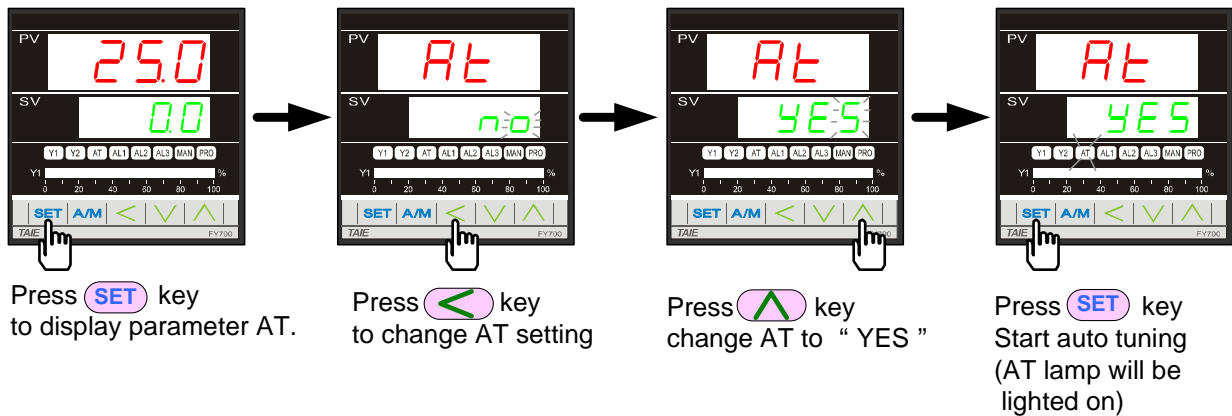

Autotuning
ATVL=0

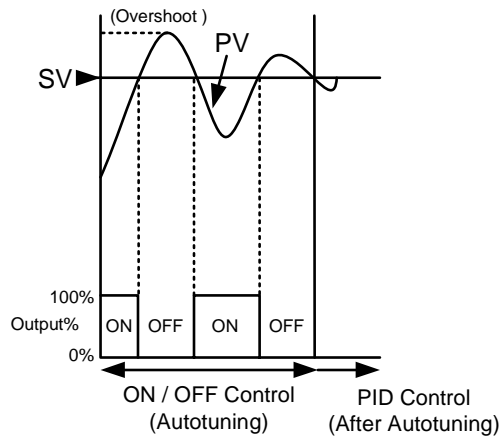

Autotuning
ATVL=20

*Set ATVL to prevent overshoot occurred during autotuning process.

To set ATVL ,press **SET** key 5 seconds to enter Level 2 (PID Level) and then change the value.

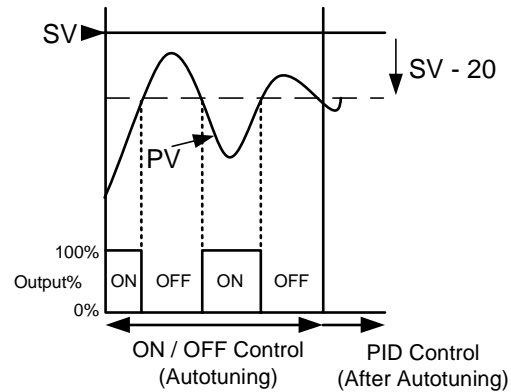

Autotuning failure

Possible cause 1 : ATVL is too big. (If not sure , set ATVL=0)

Possible cause 2 : Calculation time is too long.
(Set PID parameter manually)

6.5 Programmable RAMP / SOAK (Only available for PFY model)

*For detail of the programmable instruction, please refer with page 25.

Assume the temperature profile is as below (use total 4 segments)

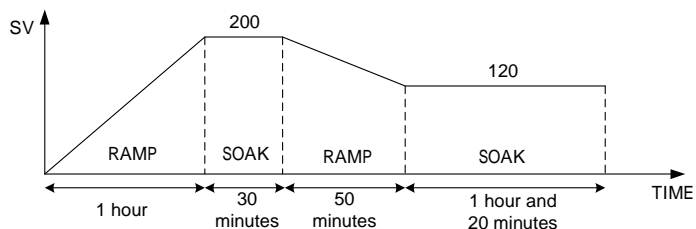

Please operate controller as following steps:

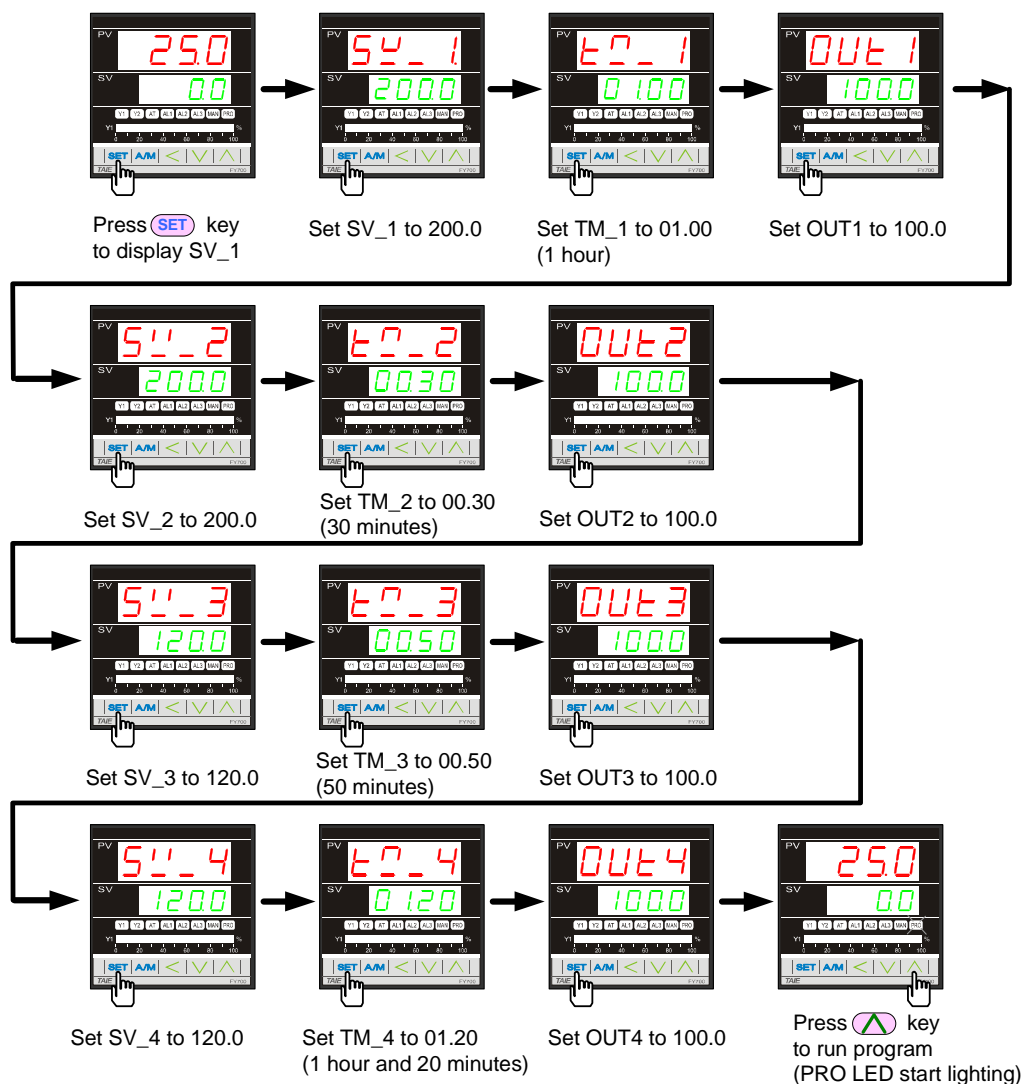

7. Operation levels

7.1 Levels diagram

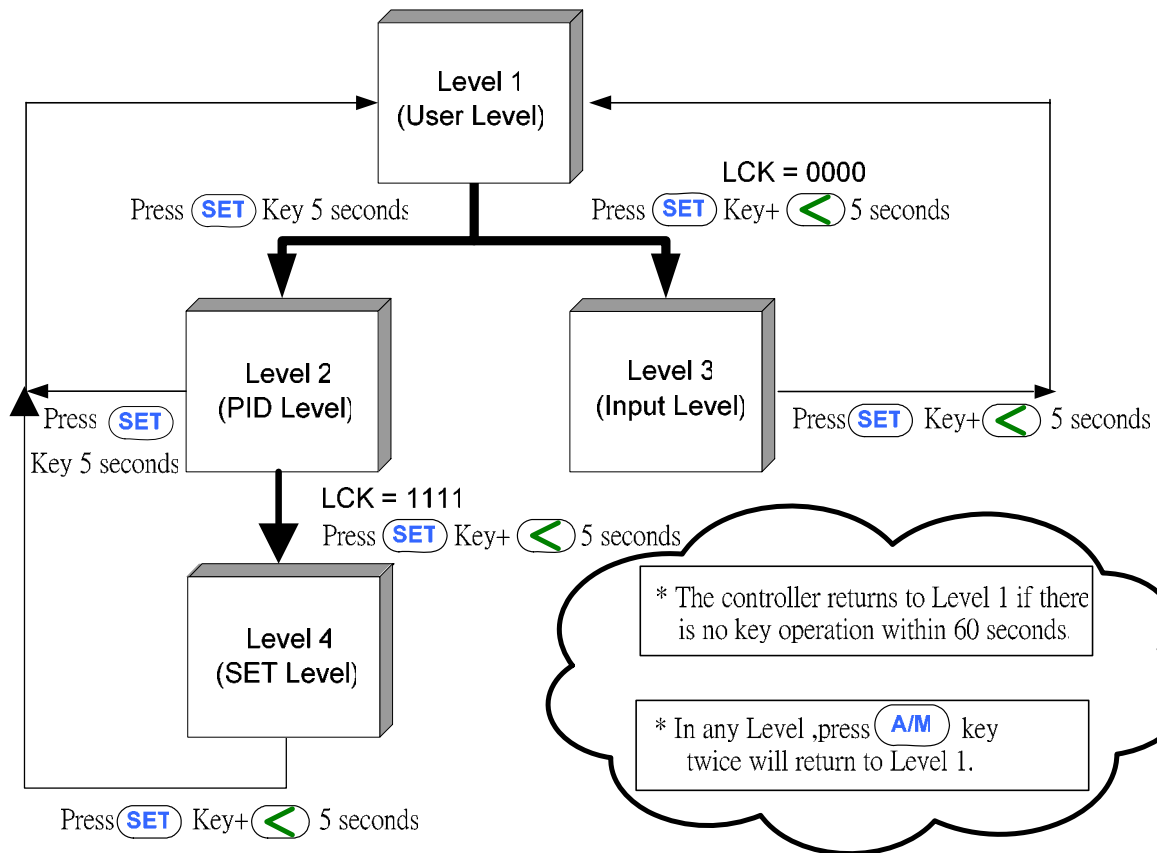

7.2 Lock function

To use lock function, please set parameter "LCK" in level 2.

LCK	Levels entering available				Parameters which can be changed
	Level 1 (User)	Level 2 (PID)	Level 3 (Input)	Level 4 (SET)	
0000				-----	All parameters (Factory set value)
1111			-----		All parameters
0100			-----	-----	All parameters except level 3
0110			-----	-----	Parameters in level 1
0001			-----	-----	"SV" and "LCK"
0101			-----	-----	Only "LCK"

8. Parameters

8.1 Level 1 (User Level)

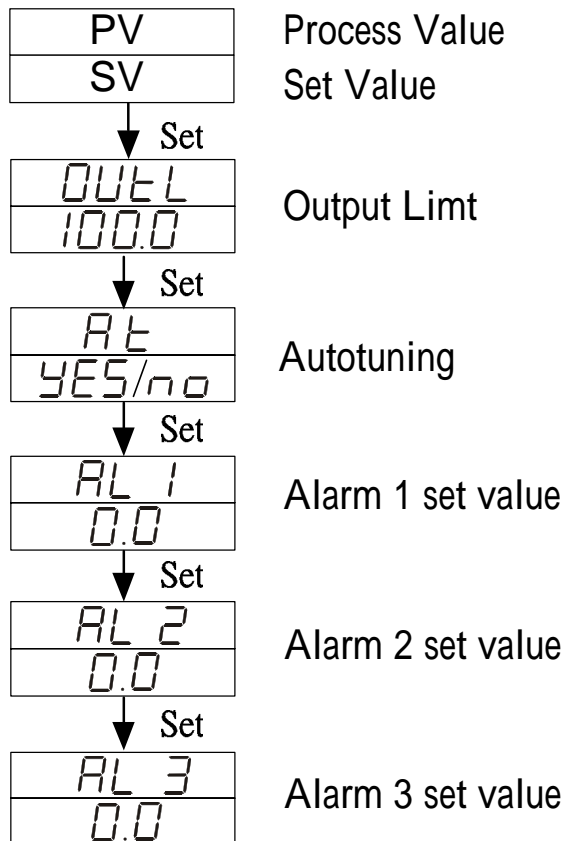

8.2 LEVEL 2 (PID Level)

To enter level 2, press SET key 5 seconds in level 1

8.2.1 Level 2 parameters display /hiding condition

1. Press **SET** key 5 seconds to enter level 2.
2. Set LCK to "1111".
3. Press **SET** key and **◀** key 5 seconds, to enter level 4 (Set level).
4. Set **OUTY** to "0" (Single output-P1).

1. Press **SET** key 5 seconds to enter level 2.
2. Set LCK to "1111".
3. Press **SET** key and **◀** key 5 seconds, to enter level 4 (Set level).
4. Set **OUTY** to "1" (Dual output - P1/P2).

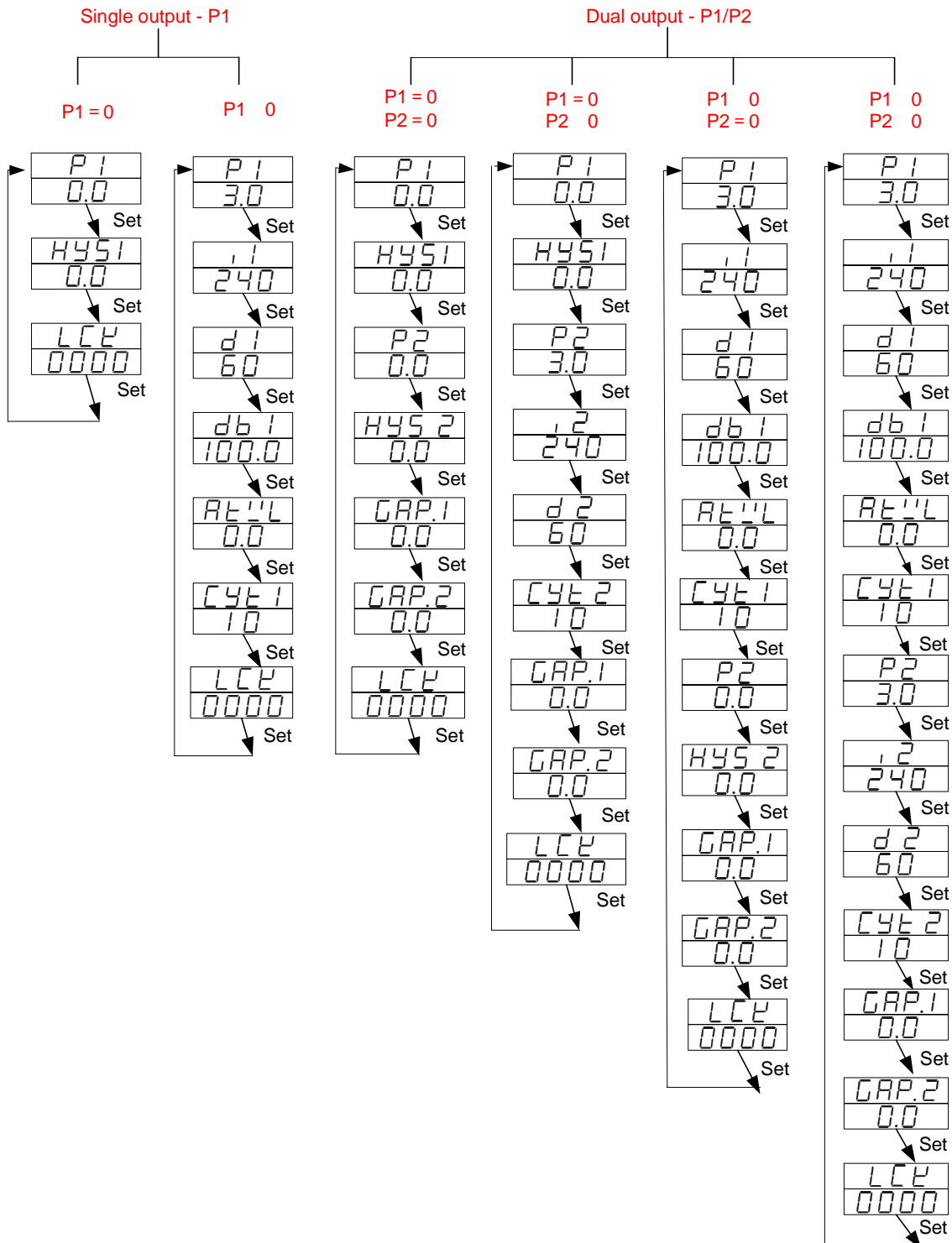

8.2.2 Description of parameters

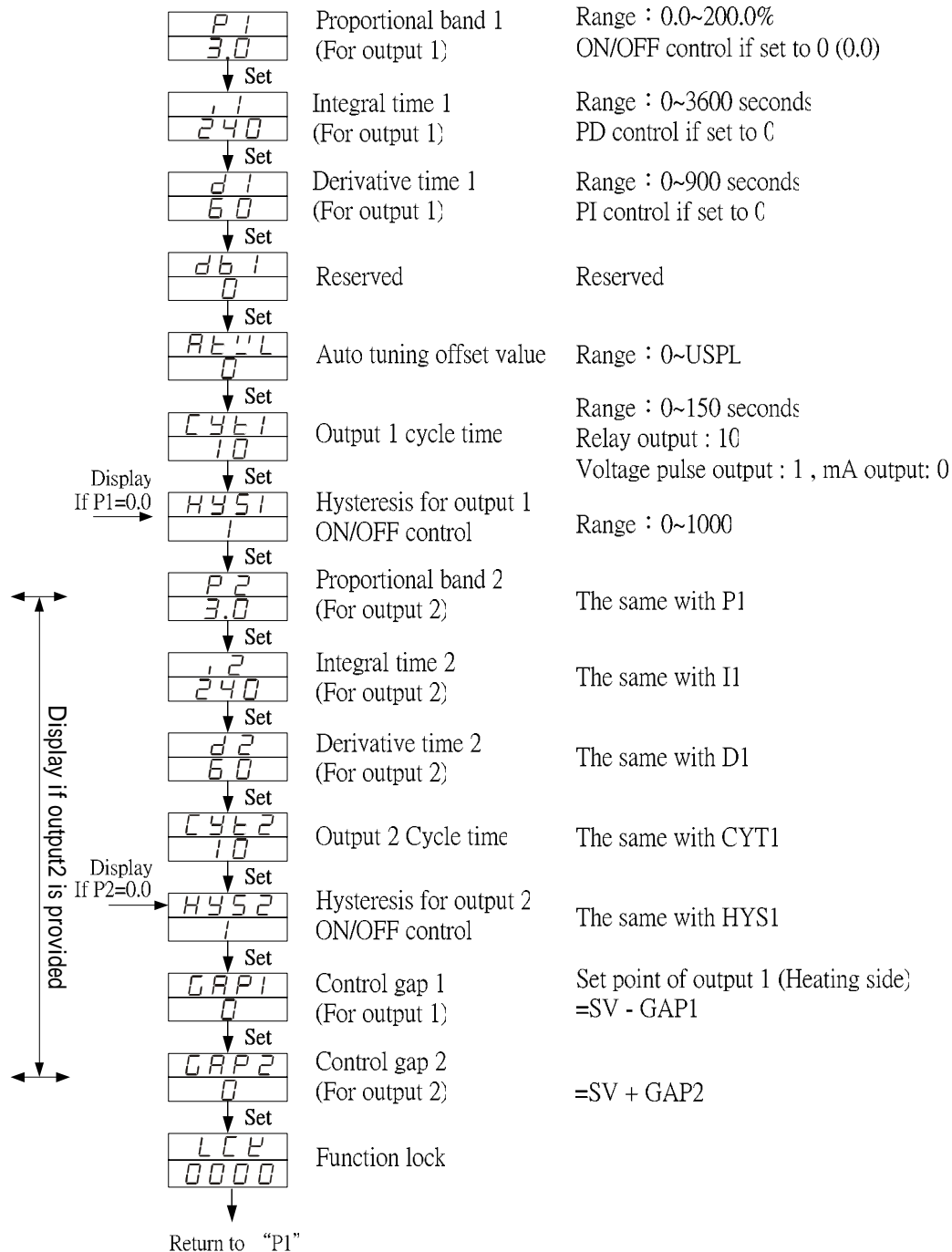

LCK	Levels entering available				Parameters which can be changed
	Level 1 (User)	Level 2 (PID)	Level 3 (Input)	Level 4 (SET)	
0000				-----	All parameters (default value)
1111			-----		All parameters
0100			-----	-----	All parameters except level 3
0110			-----	-----	Parameters in level 1
0001			-----	-----	"SV" and "LCK"
0101			-----	-----	Only "LCK"

8.3 LEVEL 3 (Input Level)

To enter level 3 , set LCK to "0000" and then press SET key + Shift() key 5 seconds.

<div style="border: 1px solid black; padding: 2px; width: fit-content; margin: 0 auto;">INP1</div> <div style="border: 1px solid black; padding: 2px; width: fit-content; margin: 0 auto;">22</div>	Input type selection	
↓ Set		
<div style="border: 1px solid black; padding: 2px; width: fit-content; margin: 0 auto;">ANL1</div> <div style="border: 1px solid black; padding: 2px; width: fit-content; margin: 0 auto;">0</div>	Analog input low limit calibration (Used for mA and V input)	Range : -1999 ~ 9999
↓ Set		
<div style="border: 1px solid black; padding: 2px; width: fit-content; margin: 0 auto;">ANH1</div> <div style="border: 1px solid black; padding: 2px; width: fit-content; margin: 0 auto;">5000</div>	Analog input high limit calibration (Used for mA and V input)	Range : 0 ~ 9999
↓ Set		
<div style="border: 1px solid black; padding: 2px; width: fit-content; margin: 0 auto;">dP</div> <div style="border: 1px solid black; padding: 2px; width: fit-content; margin: 0 auto;">0000</div>	Decimal point position (Available for mA and V input)	0000 , 000.0 , 00.00 , 0.000
↓ Set		
<div style="border: 1px solid black; padding: 2px; width: fit-content; margin: 0 auto;">L.S.P.L</div> <div style="border: 1px solid black; padding: 2px; width: fit-content; margin: 0 auto;">0.0</div>	Lower Set-Point Limit	Scaling Low Limit
↓ Set		
<div style="border: 1px solid black; padding: 2px; width: fit-content; margin: 0 auto;">U.S.P.L</div> <div style="border: 1px solid black; padding: 2px; width: fit-content; margin: 0 auto;">400.0</div>	Upper Set-Point Limit	Scaling High Limit
↓ Set		
<div style="border: 1px solid black; padding: 2px; width: fit-content; margin: 0 auto;">ANL2</div> <div style="border: 1px solid black; padding: 2px; width: fit-content; margin: 0 auto;">0</div>	Remote input low limit calibration	Range : -1999 ~ 9999
↓ Set		
<div style="border: 1px solid black; padding: 2px; width: fit-content; margin: 0 auto;">ANH2</div> <div style="border: 1px solid black; padding: 2px; width: fit-content; margin: 0 auto;">5000</div>	Remote input high limit calibration	Range : 0 ~ 9999
↓ Set		
<div style="border: 1px solid black; padding: 2px; width: fit-content; margin: 0 auto;">ALd1</div> <div style="border: 1px solid black; padding: 2px; width: fit-content; margin: 0 auto;">11</div>	Alarm mode of AL1	Range:00~19 Refer to "Alarm mode type"
↓ Set		
<div style="border: 1px solid black; padding: 2px; width: fit-content; margin: 0 auto;">ALt1</div> <div style="border: 1px solid black; padding: 2px; width: fit-content; margin: 0 auto;">99.59</div>	Alarm time of AL1	Range : 0~99 Min 59 Secs 0=Flicker Alarm , 99:59=Continued Others=On delay time (If ALD=07 , ALT means alarm on time)
↓ Set		
<div style="border: 1px solid black; padding: 2px; width: fit-content; margin: 0 auto;">ALd2</div> <div style="border: 1px solid black; padding: 2px; width: fit-content; margin: 0 auto;">0</div>	Alarm mode of AL2	The same with ALD1
↓ Set		
<div style="border: 1px solid black; padding: 2px; width: fit-content; margin: 0 auto;">ALt2</div> <div style="border: 1px solid black; padding: 2px; width: fit-content; margin: 0 auto;">99.59</div>	Alarm time of AL2	The same with ALT1
↓ Set		
<div style="border: 1px solid black; padding: 2px; width: fit-content; margin: 0 auto;">ALd3</div> <div style="border: 1px solid black; padding: 2px; width: fit-content; margin: 0 auto;">0</div>	Alarm mode of AL3	The same with ALD1
↓ Set		
<div style="border: 1px solid black; padding: 2px; width: fit-content; margin: 0 auto;">ALt3</div> <div style="border: 1px solid black; padding: 2px; width: fit-content; margin: 0 auto;">99.59</div>	Alarm time of AL3	The same with ALT1
↓ Set		
<div style="border: 1px solid black; padding: 2px; width: fit-content; margin: 0 auto;">HYSA</div> <div style="border: 1px solid black; padding: 2px; width: fit-content; margin: 0 auto;">0.0</div>	Hysteresis of all Alarm	Range : 0~1000
↓ Set		
<div style="border: 1px solid black; padding: 2px; width: fit-content; margin: 0 auto;">CLO1</div> <div style="border: 1px solid black; padding: 2px; width: fit-content; margin: 0 auto;">230</div>	Output 1 low limit calibration (Used for mA and V output)	Range : 0 ~ 9999
↓ Set		

<div style="border: 1px solid black; padding: 2px; display: inline-block;">CH01</div> <div style="border: 1px solid black; padding: 2px; display: inline-block;">3600</div> ↓ Set	Output 1 high limit calibration (Used for mA and V output)	Range : 0 ~ 9999
<div style="border: 1px solid black; padding: 2px; display: inline-block;">CLO2</div> <div style="border: 1px solid black; padding: 2px; display: inline-block;">230</div> ↓ Set	Output 2 low limit calibration (Used for mA and V output)	The same with CLO1
<div style="border: 1px solid black; padding: 2px; display: inline-block;">CH02</div> <div style="border: 1px solid black; padding: 2px; display: inline-block;">3600</div> ↓ Set	Output 2 high limit calibration (Used for mA and V output)	The same with CHO1
<div style="border: 1px solid black; padding: 2px; display: inline-block;">CLO3</div> <div style="border: 1px solid black; padding: 2px; display: inline-block;">0</div> ↓ Set	Retransmission low limit calibration	The same with CLO1
<div style="border: 1px solid black; padding: 2px; display: inline-block;">CH03</div> <div style="border: 1px solid black; padding: 2px; display: inline-block;">5000</div> ↓ Set	Retransmission high limit calibration	The same with CHO1
<div style="border: 1px solid black; padding: 2px; display: inline-block;">r.u.c.y</div> <div style="border: 1px solid black; padding: 2px; display: inline-block;">5</div> ↓ Set	Full run time of proportional motor (Used for proportional motor valve control output)	Range : 5~200 seconds
<div style="border: 1px solid black; padding: 2px; display: inline-block;">w.a.i.t</div> <div style="border: 1px solid black; padding: 2px; display: inline-block;">0.0</div> ↓ Set	Used for programmable controller to wait continued operation	0=Not wait Others=Wait value
<div style="border: 1px solid black; padding: 2px; display: inline-block;">S.E.T.A</div> <div style="border: 1px solid black; padding: 2px; display: inline-block;">0000</div> ↓ Set		
<div style="border: 1px solid black; padding: 2px; display: inline-block;">I.d.N.O</div> <div style="border: 1px solid black; padding: 2px; display: inline-block;">1</div> ↓ Set	ID number	Range : 0 ~ 99
<div style="border: 1px solid black; padding: 2px; display: inline-block;">b.A.U.d</div> <div style="border: 1px solid black; padding: 2px; display: inline-block;">2400</div> ↓ Set	Baudrate	110 / 300 / 1200 / 2400 / 4800 / 9600 bps
<div style="border: 1px solid black; padding: 2px; display: inline-block;">S.V.O.S</div> <div style="border: 1px solid black; padding: 2px; display: inline-block;">0.0</div> ↓ Set	SV compensation	Range : -1000~1000
<div style="border: 1px solid black; padding: 2px; display: inline-block;">P.V.O.S</div> <div style="border: 1px solid black; padding: 2px; display: inline-block;">0.0</div> ↓ Set	PV compensation	Range : -1000~1000
<div style="border: 1px solid black; padding: 2px; display: inline-block;">U.N.I.T</div> <div style="border: 1px solid black; padding: 2px; display: inline-block;">C</div> ↓ Set	Unit of PV & SV	C(°C) / F(°F) / A(Analog)
<div style="border: 1px solid black; padding: 2px; display: inline-block;">S.O.F.T</div> <div style="border: 1px solid black; padding: 2px; display: inline-block;">0.200</div> ↓ Set	Soft Filter	
<div style="border: 1px solid black; padding: 2px; display: inline-block;">C.A.S.C</div> <div style="border: 1px solid black; padding: 2px; display: inline-block;">0.0</div> ↓ Set	Reserved	
<div style="border: 1px solid black; padding: 2px; display: inline-block;">O.U.d</div> <div style="border: 1px solid black; padding: 2px; display: inline-block;">H.E.A.T</div> ↓ Set	Action mode	Heat / Cool
<div style="border: 1px solid black; padding: 2px; display: inline-block;">O.P.A.d</div> <div style="border: 1px solid black; padding: 2px; display: inline-block;">P.i.d</div> ↓ Set	Control algorithm	PID / Fuzzy
<div style="border: 1px solid black; padding: 2px; display: inline-block;">H =</div> <div style="border: 1px solid black; padding: 2px; display: inline-block;">60H =</div> ↓ Set	Frequency	50 / 60HZ

Return to "INP1"

8.4 Level 4 (SET level)

To enter level 4, set LCK to "1111" and then press SET key + Shift(◀) key 5 seconds.

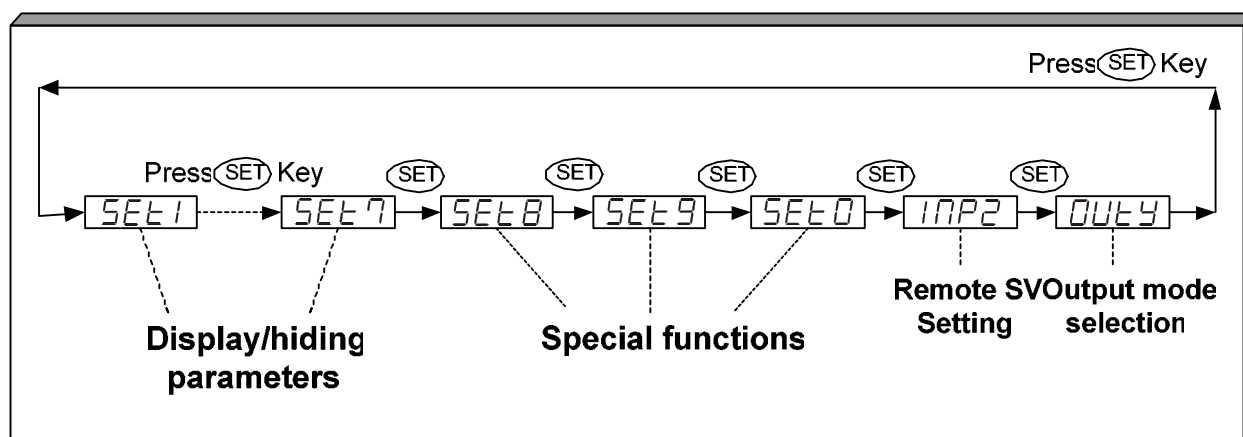

8.4.1 How to hide parameters (Use SET1~SET7)

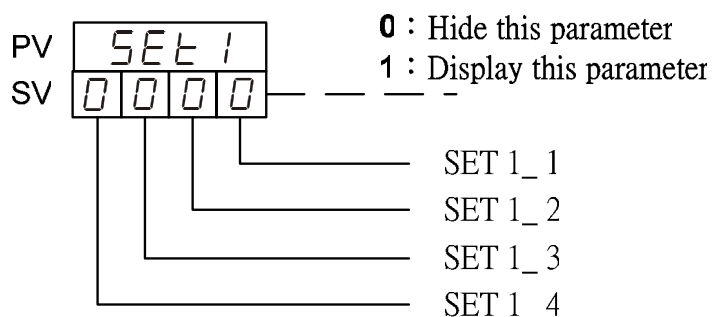

*For the description of Level 1 parameters, please refer with page 17.

*For the description of Level 3 parameters, please refer with page 20.

SET	Display / hiding	Level	SET	Display / hiding	Level
1_1	OUTL	Level 1	5_1	CL02,CH02	Level 3
1_2	AL	Level 1	5_2	CL03,CH03	Level 3
1_3	AL 1	Level 1	5_3	FUCY,DATE,SEtA	Level 3
1_4	AL 2	Level 1	5_4	Id.NO,BAUD	Level 3
2_1	AL 3	Level 1	6_1	S'OS	Level 3
2_2	ANL1,ANH1,dP	Level 3	6_2	P'OS	Level 3
2_3	L.SPL,U.SPL	Level 3	6_3	UNIT	Level 3
2_4	ANL2,ANH2	Level 3	6_4	SOFT	Level 3
3_1	ALd1	Level 3	7_1	CASC	Level 3
3_2	ALt1	Level 3	7_2	OUd	Level 3
3_3	ALd2	Level 3	7_3	OPAd	Level 3
3_4	ALt2	Level 3	7_4	H =	Level 3
4_1	ALd3	Level 3			
4_2	ALt3	Level 3			
4_3	HYSR	Level 3			
4_4	CL01,CH01	Level 3			

8.4.2 Special functions (Use SET8 / SET9 / SET0)

SET 8		Remark
8_1	0 : Program not repeat	Only available for programmable controller
	1 : Program repeat	
8_2	0 : No power failure option	
	1 : With power failure option	
8_3	0 : Program starts from 0	
	1 : Program starts from PV	
8_4	0 : Reserved (Don't change it)	

SET 9		Remark
9_1	0 : Reserved (Don't change it)	
9_2	0 : Timer Unit = "Hour : Minute"	Only available for programmable controller
	1 : Timer Unit = "Minute : Second"	
9_3	0 : Disable transmission	Used for transmission output
	1 : SV Transmission	
9_4	0 : Disable transmission	
	1 : PV Transmission	

SET 0		Remark
0_1	0 : TTL Communication (Slave)	Used for TTL communication
	1 : TTL Communication (Master)	
0_2	0 : Hide parameter "RATE"	AL3 will be replaced by "RATE"
	1 : Display parameter "RATE"	
0_3	0 : Disable Remote SV function	Used for Remote SV function
	1 : Enable Remote SV function	
0_4	0 : use output relay "b" contact when motor valve closed	Used for 3 wire proportional motor valve control
	1 : use output relay "a" contact when motor valve closed	

Please don't operate **SET 8_4** , otherwise the controller's process will be in confusion.

If SET8.4 is set to “1”, the controller will enter into “Single Display” mode, the PV LED will not display any values. The SV LED will display both the parameter value and the setting value alternately as shown in the diagram below.

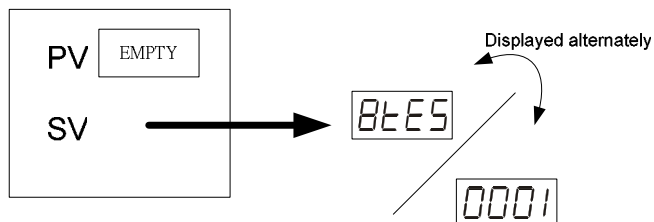

To rectify the problem please press the SHIFT KEY () and change the setting value to “0000”.

8.4.3 Remote SV type selection

INP2=0 None.

INP2=1 10~50mV / 4~20mA / 1~5V / 2~10V。

INP2=2 0~50mV / 0~20mA / 0~5V / 0~10V。

Remote SV function is not available for programmable controller

8.4.4 Output mode selection (Use OUTY)

OUTY=0 Single output (OUT1)

OUTY=1 Dual output (OUT1 / OUT2)

OUTY=2 Reserved

OUTY=3 3 wire proportional motor valve control

OUTY=4 1 ψ Phase angle control (1 ψ SCR)

OUTY=5 3 ψ Phase angle control (3 ψ SCR)

8.5 Program Level (Only displayed in programmable controller)

8.5.1 Description of parameters

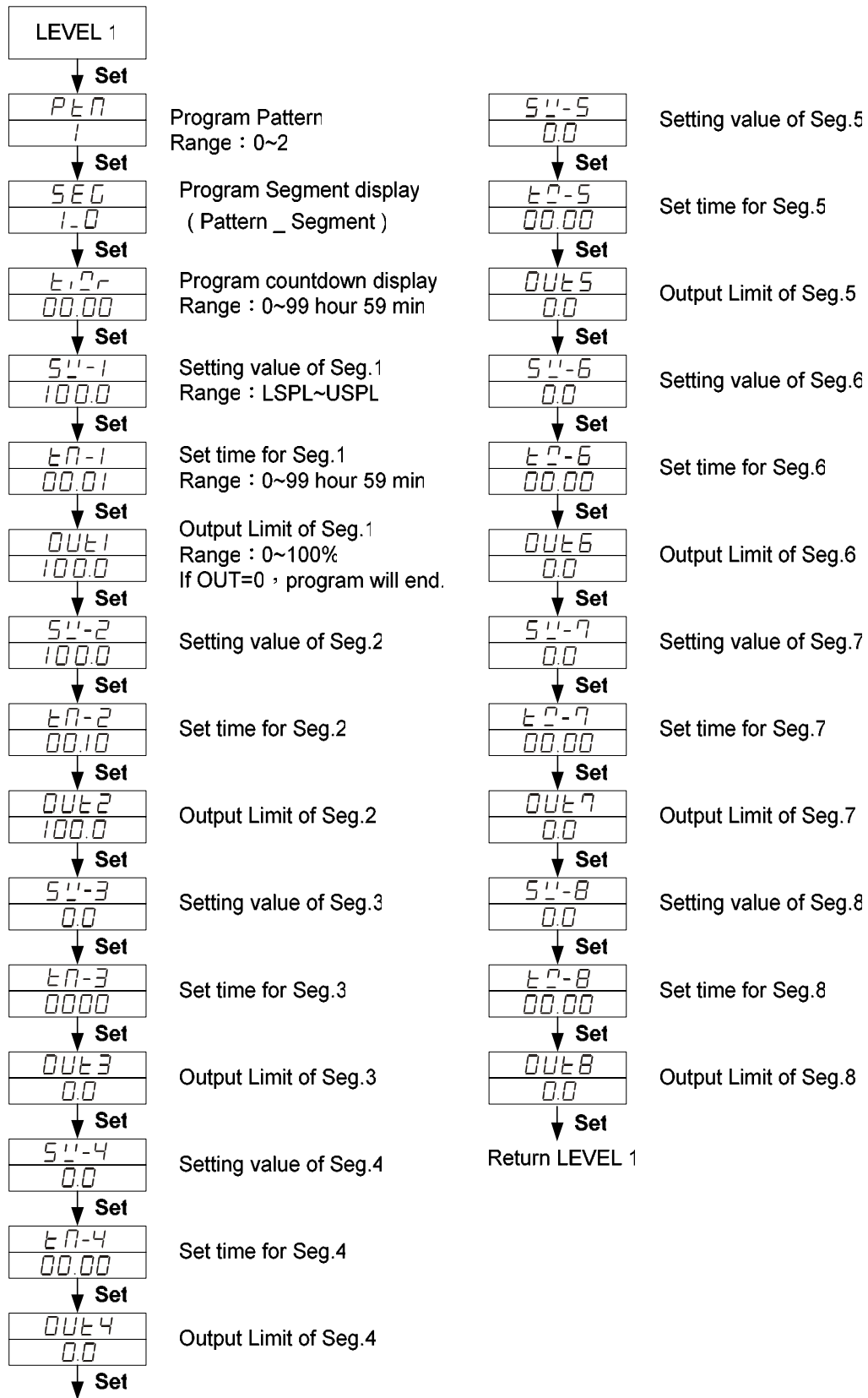

8.5.2 Description of operation

1. There are 2 patterns can be used , each pattern contains 8 segments.

2. Terminologies

Pattern : A program consists of some steps.

Ramp status : The status with changing SV.

Soak status : The status with fixed SV.

3. Operating

I. "KEY" function (no changing parameter)

 (RUN) : Start program procedure , **PRO** LED in panel start flicking.

 (HOLD) : Suspend program procedure , **PRO** LED in panel will stop flicker but still light on.

 + **SET**(JUMP) : Jump to previous segment.

 + **SET** (RESET) : Reset program procedure , **PRO** LED in panel will off.

II. Alarm Function :

ALD1 = "07"(Segment end alarm) ,

AL1 ="2"(It means when segment 2 end,AL1 will act) ,

ALT1 ="00:10"(Relay on time is 10 seconds).

* In this case , when program proceeds to segment 2 end , the relay of AL1 will be on 10 seconds.

III. END function :

The Controller doesn't have END order, so if program procedure is less than 8 segments, please set the last segment's OUT to "0". Program will end in this segment. Otherwise , it will proceed 8 or 16 segments.

IV. Linking Function :

PTN=1 proceed pattern 1 , contains 8 segments.

PTN=2 proceed pattern 2 , contains 8 segments.

PTN=0 linking proceed pattern 1 and 2 totally 16 segments.

(Please set PTN1 and PTN2 at first , and then set PTN to 0)

V. Other function(* refer to LEVEL 4)

SET 8_1=1 Program repeats.

SET 8_2=0 No power failure function.

SET 8_2=1 Enable power failure function.

(When power shut down and on again , the controller will start from the segment which is near PV)

SET 8_3=0 Program starts from 0.

SET 8_3=1 Program starts from PV.

9. Input type table (INP1 selection)

TYPE	CODE	RANGE
K	<i>K1</i>	0.0 ~ 200.0 / 0.0 ~392.0
	<i>K2</i>	0.0 ~ 400.0 / 0.0 ~752.0
	<i>K3</i>	0 ~ 600 / 0 ~1112
	<i>K4</i>	0 ~ 800 / 0 ~1472
	<i>K5</i>	0 ~ 1000 / 0 ~1832
	<i>K6</i>	0 ~ 1200 / 0 ~2192
J	<i>J1</i>	0.0 ~ 200.0 / 0.0 ~392.0
	<i>J2</i>	0.0 ~ 400.0 / 0.0 ~752.0
	<i>J3</i>	0 ~ 600 / 0 ~1112
	<i>J4</i>	0 ~ 800 / 0 ~1472
	<i>J5</i>	0 ~ 1000 / 0 ~1832
	<i>J6</i>	0 ~ 1200 / 0 ~2192
R	<i>r1</i>	0 ~ 1600 / 0 ~2912
	<i>r2</i>	0 ~ 1769 / 0 ~3216
S	<i>S1</i>	0 ~ 1600 / 0 ~2912
	<i>S2</i>	0 ~ 1769 / 0 ~3216
B	<i>b1</i>	0 ~ 1820 / 0 ~3308
E	<i>E1</i>	0 ~ 800 / 0 ~1472
	<i>E2</i>	0 ~ 1000 / 0 ~1832
N	<i>n1</i>	0 ~ 1200 / 0 ~2192
	<i>n2</i>	0 ~ 1300 / 0 ~2372
T	<i>t1</i>	0.0 ~ 400.0 / 0.0 ~752.0
	<i>t2</i>	0.0 ~ 200.0 / 0.0 ~392.0
	<i>t3</i>	0.0 ~ 350.0 / 0.0 ~662.0
W	<i>w1</i>	0 ~ 2000 / 0 ~3632
	<i>w2</i>	0 ~ 2320 / 0 ~4208
PL	<i>PL1</i>	0 ~ 1300 / 0 ~2372
	<i>PL2</i>	0 ~ 1390 / 0 ~2534
U	<i>U1</i>	-199.9 ~ 600.0 / -199.9 ~999.9
	<i>U2</i>	-199.9 ~ 200.0 / -199.9 ~392.0
	<i>U3</i>	0.0 ~ 400.0 / 0.0 ~752.0
L	<i>L1</i>	0 ~ 400 / 0 ~752
	<i>L2</i>	0 ~ 800 / 0 ~1472

TYPE	CODE	RANGE
JIS PT100	<i>JP1</i>	-199.9 ~ 600.0 / -199.9 ~ 999.9
	<i>JP2</i>	-199.9 ~ 400.0 / -199.9 ~ 752.0
	<i>JP3</i>	-199.9 ~ 200.0 / -199.9 ~ 392.0
	<i>JP4</i>	0 ~ 200 / 0 ~ 392
	<i>JP5</i>	0 ~ 400 / 0 ~ 752
	<i>JP6</i>	0 ~ 600 / 0 ~ 1112
DIN PT100	<i>dP1</i>	-199.9 ~ 600.0 / -199.9 ~ 999.9
	<i>dP2</i>	-199.9 ~ 400.0 / -199.9 ~ 752.0
	<i>dP3</i>	-199.9 ~ 200.0 / -199.9 ~ 392.0
	<i>dP4</i>	0 ~ 200 / 0 ~ 392
	<i>dP5</i>	0 ~ 400 / 0 ~ 752
	<i>dP6</i>	0 ~ 600 / 0 ~ 1112
JIS PT50	<i>dP.1</i>	-199.9 ~ 600.0 / -199.9 ~ 999.9
	<i>dP.2</i>	-199.9 ~ 400.0 / -199.9 ~ 752.0
	<i>dP.3</i>	-199.9 ~ 200.0 / -199.9 ~ 392.0
	<i>dP.4</i>	0 ~ 200 / 0 ~ 392
	<i>dP.5</i>	0 ~ 400 / 0 ~ 752
	<i>dP.6</i>	0 ~ 600 / 0 ~ 1112
AN1	<i>AN1</i>	-10 ~ 10mV / -1999~9999
AN2	<i>AN2</i>	0 ~ 10mV / -1999~9999
AN3	<i>AN3</i>	0 ~ 20mV / -1999~9999
AN4	<i>AN4</i>	0 ~ 50mV / -1999~9999
AN5	<i>AN5</i>	10 ~ 50mV / -1999~9999

* The initial setting in factory is "K2".

10. Alarm

10.1 Alarm time (ALT1/ALT2/ALT3)

ALT1=0 Flicker alarm
ALT1=99.59 Continued alarm
ALT1=00.01 ~ 99.58 Alarm on delay time

10.2 SETA

*SETA is in Level 3 (Input level)

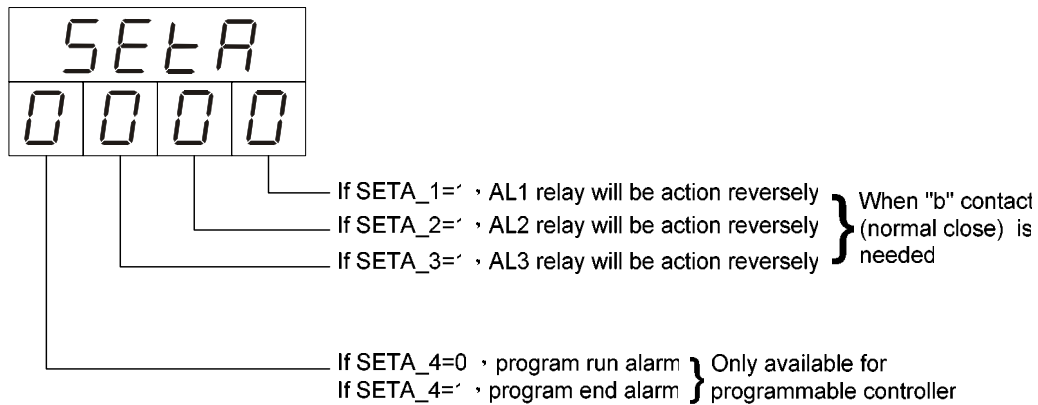

10.3 Alarm mode (ALD1 / ALD2 / ALD3)

(▲ :SV △ :Alarm set value)

01	Deviation high alarm with hold action* OFF ON ▲ △ HIGH → PV	06	Process low alarm with hold action* ON OFF LOW △ HIGH → PV
11	Deviation high alarm OFF ON ▲ △ HIGH → PV	16	Process low alarm ON OFF LOW △ HIGH → PV
02	Deviation low alarm with hold action* ON OFF ▲ △ HIGH → PV	07	Segment End alarm (Only for Programmable controller) (1) ALD1~3 , set 07 (2) ALD1~3=Alarm Segment (3) ALT1~3 defines as follows: 0 =flicker alarm 99.59 =continued alarm others =alarm ON time
12	Deviation low alarm ON OFF ▲ △ HIGH → PV	17	Program Run alarm (Only for Programmable controller) Run Stop ON OFF → AL
03	Deviation high/low alarm with hold action* ON OFF ON LOW △ ▲ △ HIGH → PV	08	System failed alarm* (ON) Normal Failed OFF ON → AL
13	Deviation high/low alarm ON OFF ON LOW △ ▲ △ HIGH → PV	18	System failed alarm* (OFF) Normal Failed ON OFF → AL
04 14	Band alarm OFF ON OFF LOW △ ▲ △ HIGH → PV	09	Soak Timer When PV=SV(soak) , the timer begins to count. When timer is up , alarm relay will be activated. Timer range = 00H.00M ~ 99H.59M
05	Process high alarm with hold action* OFF ON LOW △ HIGH → PV	00 10	No alarm
15	Process high alarm OFF ON LOW △ HIGH → PV		

***Hold action:**

When Hold action is ON ,the alarm action is suppressed at start-up until the measured value(PV) enters the non-alarm range.

***System failed:**

It means that the controller display error message with one of following :
"UUU1" or "NNN1" or "CJCE"

11. Error codes

DISPLAY	DESCRIPTION
<i>in1E</i>	Open circuit of main control sensor.(INP1)
* <i>RdCF</i>	A/D convert failed.
* <i>CJCE</i>	Cold junction compensation failed.
<i>in2E</i>	Open circuit of sub control sensor.(Remote SV)
<i>uuu1</i>	PV exceeds USPL.
<i>nnn1</i>	PV under LSPL.
<i>uuu2</i>	Input signal of sub control exceeds the upper limit. (Remote SV)
<i>nnn2</i>	Input signal of sub control under the lower limit. (Remote SV)
* <i>FRDF</i>	RAM failed.
<i>intF</i>	Interface failed.
<i>AutF</i>	Auto tuning failed.

NOTE : If the “*” marked error comes up , the controller needs to be repaired.
Please send it to the nearest sales office or retail dealer.

12. Modify input type (“TC” \rightleftharpoons “RTD”)

If the controller needs to modify input type from **TC** or **mV** to **RTD** , please make PAD short on the back side of PC board as following diagram and change input selection(INP1).
 On the contrary , modify from **RTD** to **TC** or **mV** , make PAD open.

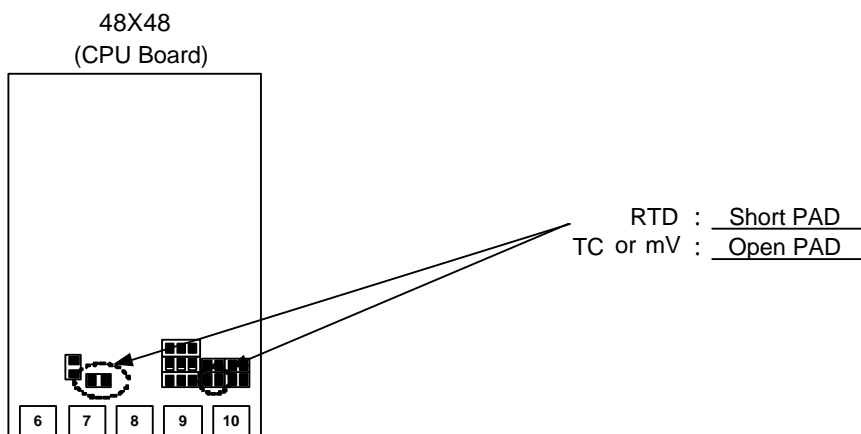
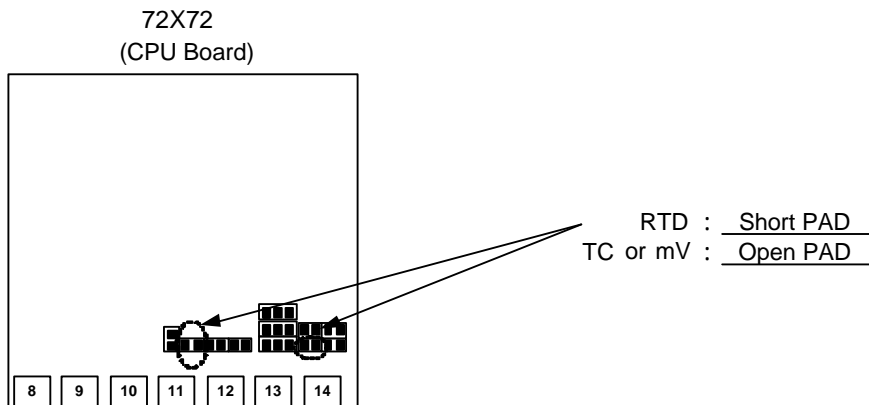
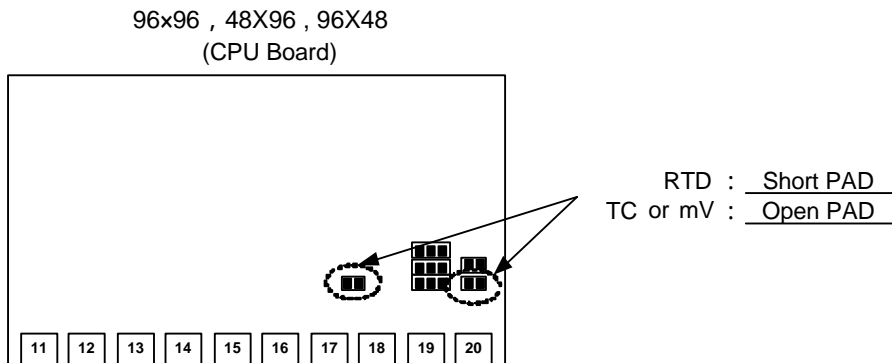

13. Modify input type : Linear Input (mA ,V)

13.1 Hardware :

	96x96 , 48x96 , 96x48	72x72	48x48
INPUT (+)	PIN 17	PIN 11	PIN 7
INPUT (-)	PIN 20	PIN 14	PIN 10

0~20mA (INP1=AN4) : (R3 use 100Ω , R5 use 2.4Ω , S3 & S5 SHORT)

4~20mA (INP1=AN5) : (R3 use 100Ω , R5 use 2.4Ω , S3 & S5 SHORT)

0 ~ 1V (INP1=AN4) : (R1 use 2KΩ , R4 use 100Ω , S1 & S4 SHORT)

0 ~ 5V (INP1=AN4) : (R2 use 10KΩ , R4 use 100Ω , S2 & S4 SHORT)

1 ~ 5V (INP1=AN5) : (R2 use 10KΩ , R4 use 100Ω , S2 & S4 SHORT)

0 ~ 10V (INP1=AN4) : (R3 use 22KΩ , R4 use 100Ω , S3 & S4 SHORT)

2 ~ 10V (INP1=AN5) : (R3 use 22KΩ , R4 use 100Ω , S3 & S4 SHORT)

96x96 , 48x96 , 96x48
(PC Board)

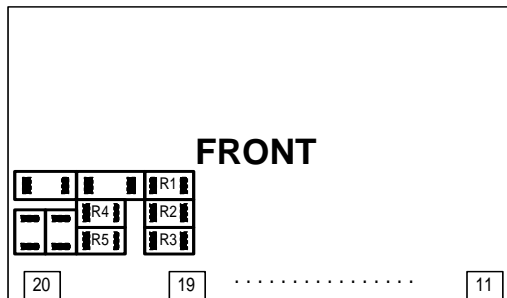

72x72
(PC Board)

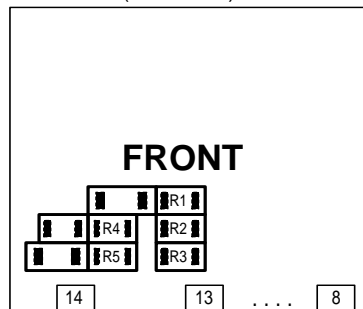

48x48
(PC Board)

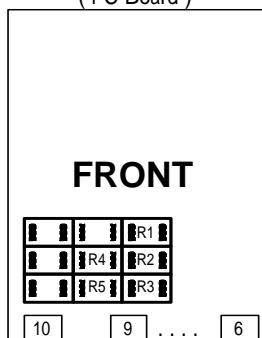

96x96 , 48x96 , 96x48
(PC Board)

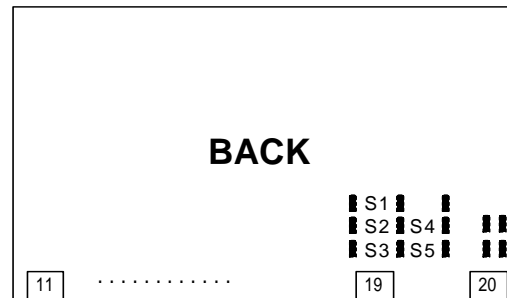

72x72
(PC Board)

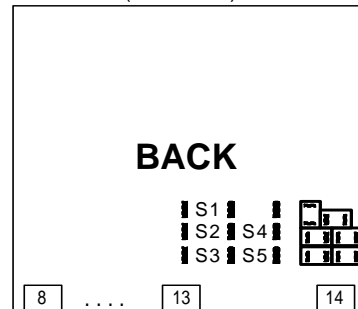

48x48
(PC Board)

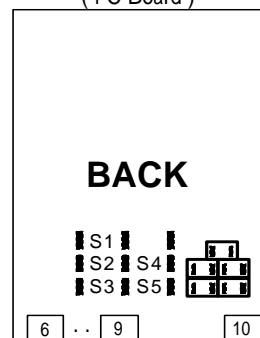

13.2 Calibration :

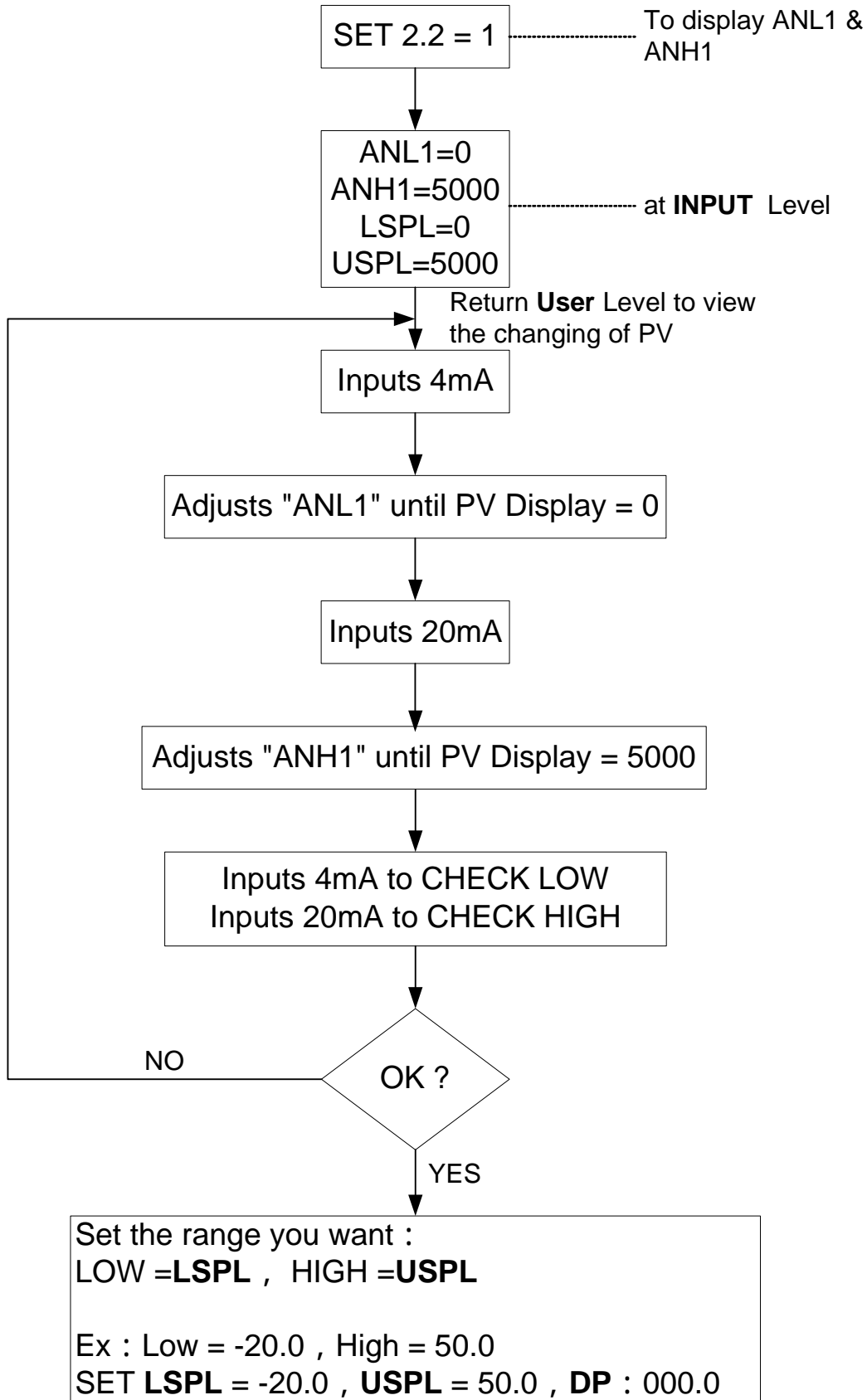

14. Modify output type: Relay, SSR, 4~20mA

It just needs to change a module at the same position ,
and modify parameter **CYT1** in LEVEL 2 .

→Relay: CYT1=10, Voltage pulse: CYT1=1, 4~20mA:CYT1=0

15. Modify output mode: OUT1/ALARM, OUT1/OUT2

OUT1 / ALARM

96x96 , 48x96 , 96x48
(CPU Board)

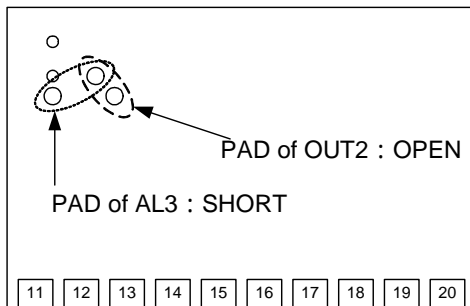

OUT1 /OUT2

96x96 , 48x96 , 96x48
(CPU Board)

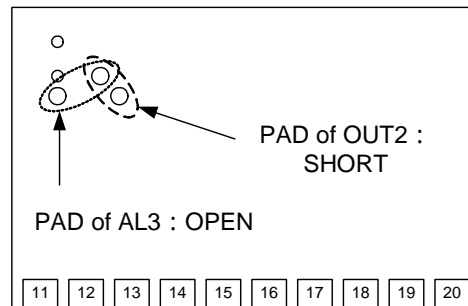

72x72
(CPU Board)

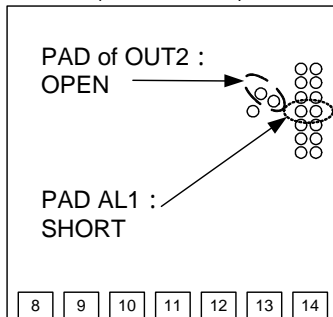

72x72
(CPU Board)

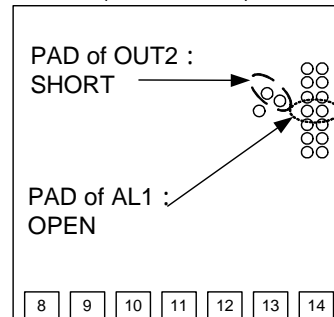

48x48
(CPU Board)

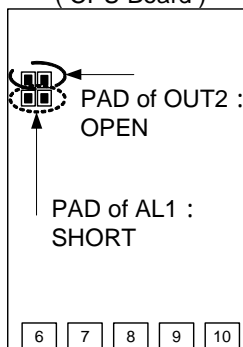

48x48
(CPU Board)

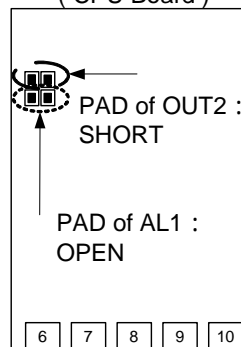

16. Applications

16.1 RAMP & SOAK

- **RAMP :**

- I. SET2.1=1 → To display AL3
- II. SET4.1=1 → To display ALD3
- III. ALD3=9 → Open RAMP option
- IV. Then, AL3 will not display. It was replaced by RAMP.

RAMP
00.00

Range : 00.00 ~ 99.99(/ min)
 (If RAMP is not used , please set ALD3 to 0)

- **SOAK :**

- I. ALD1 / ALD2=19 → To use Sock Timer.
- II. AL1 / AL2 will display as below:

AL1
00.00

Range : 00.00 ~ 99.59(Hour.Minute)

- **Example :**

SV=100 , RAMP=10.00 (/min) , AL1=00.10 min , PV=25

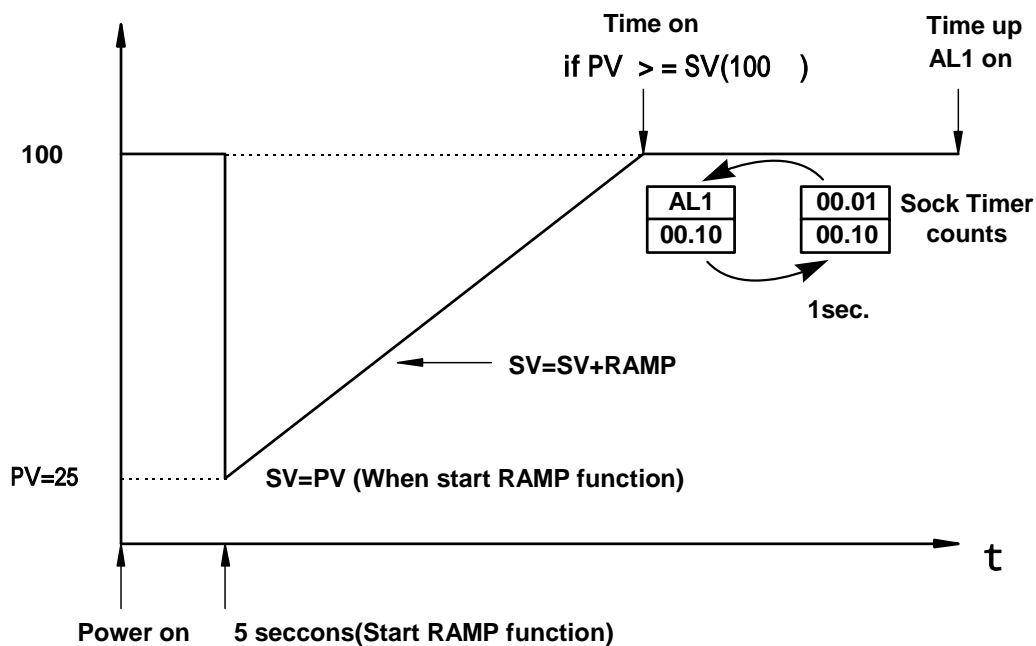

16.2 TTL Communication : SV output and RATE function

- **Open RATE function (use for slave controller)**

Display AL3 : SET2.1=1

Display ALD3 : SET4.1=1

Display RATE(AL3 will be replaced) : SET0.2=1

Set ALD3 to 0. (In Level 3)

Slave SV = (RATE÷9999)×master SV

- **Example :**

Connection Diagram

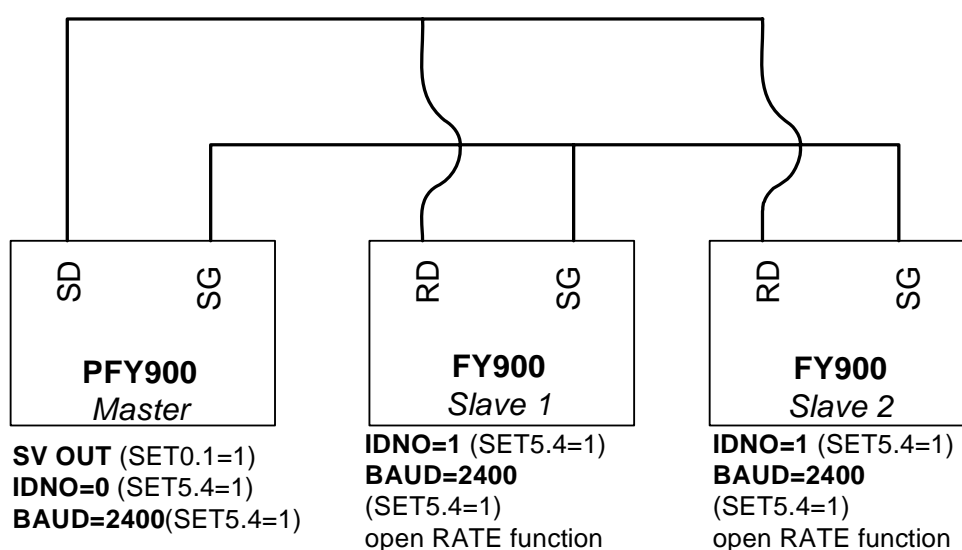

Time Chart

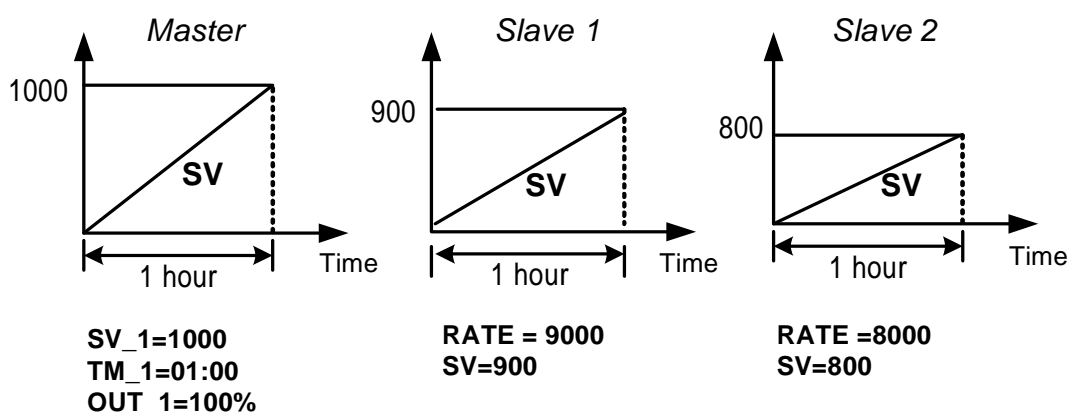

(Three controllers reach to the max value at the same time)

16.4 1 Phase angle control (By TRIAC)

- Available Models : FY900 / PFY900 , FY700 / PFY700
- OUT1: 1 SCR
- Parameter setting : OUTY=4
CLO1=0 , CHO1=4500 if use for resistance load
CLO1=0 , CHO1=4000 if use for inductor load

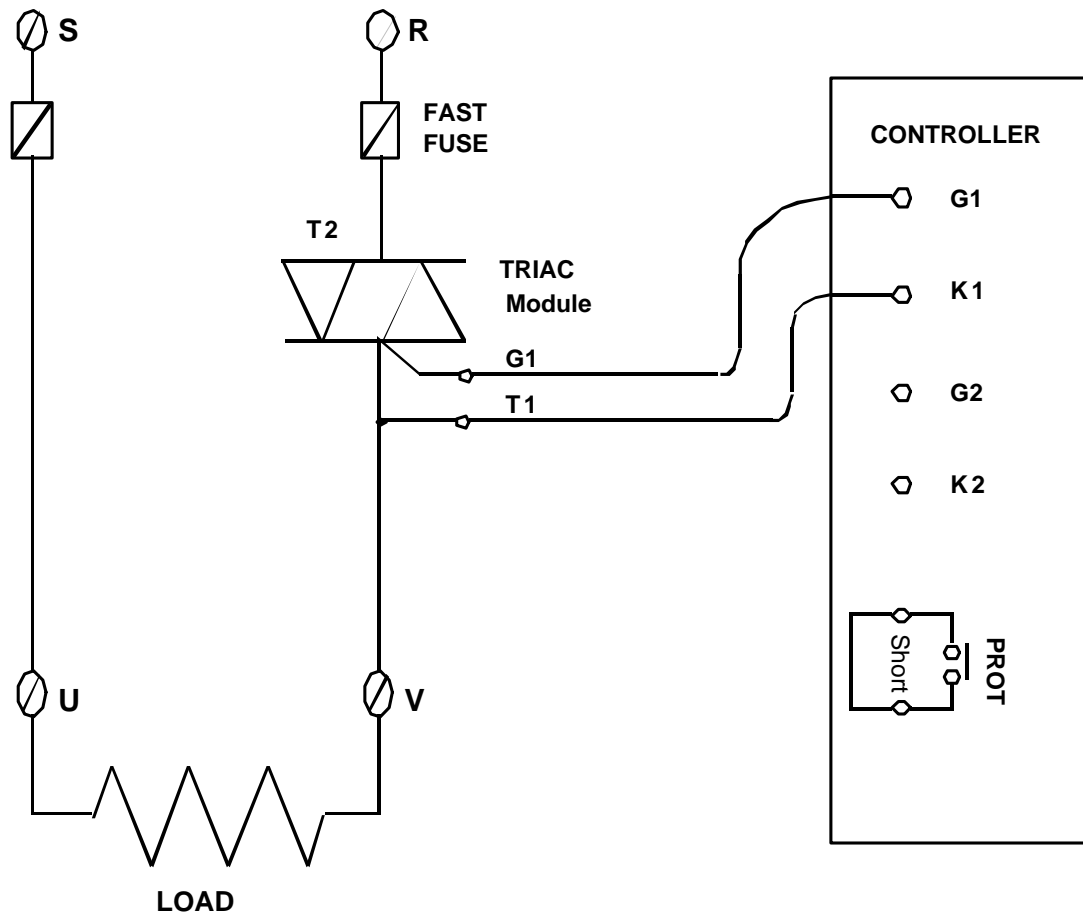

** Controller source phase must be same as load source phase

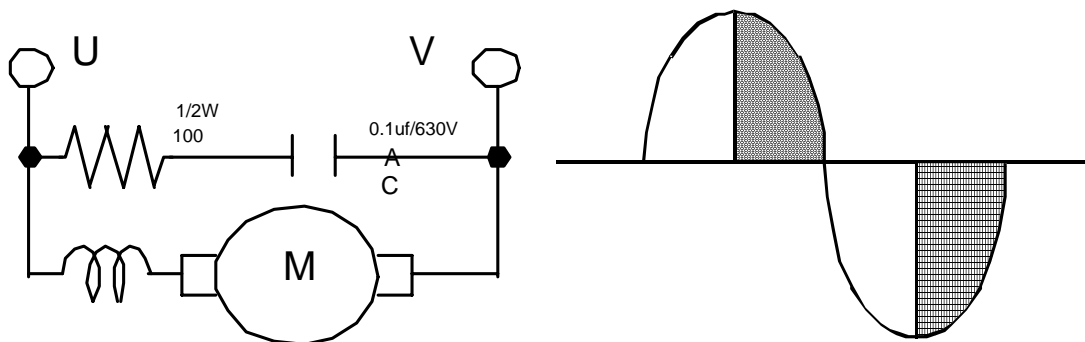

16.5 3 Phase angle control (By DIODE/SCR module)

- Available Models : FY900 / PFY900
- OUT1: 3 SCR
- Parameter setting : OUTY=5
 CLO1=0 , CHO1=4500 only if use for resistance load
 CLO1=0 , CHO1=4000 if use for inductor load

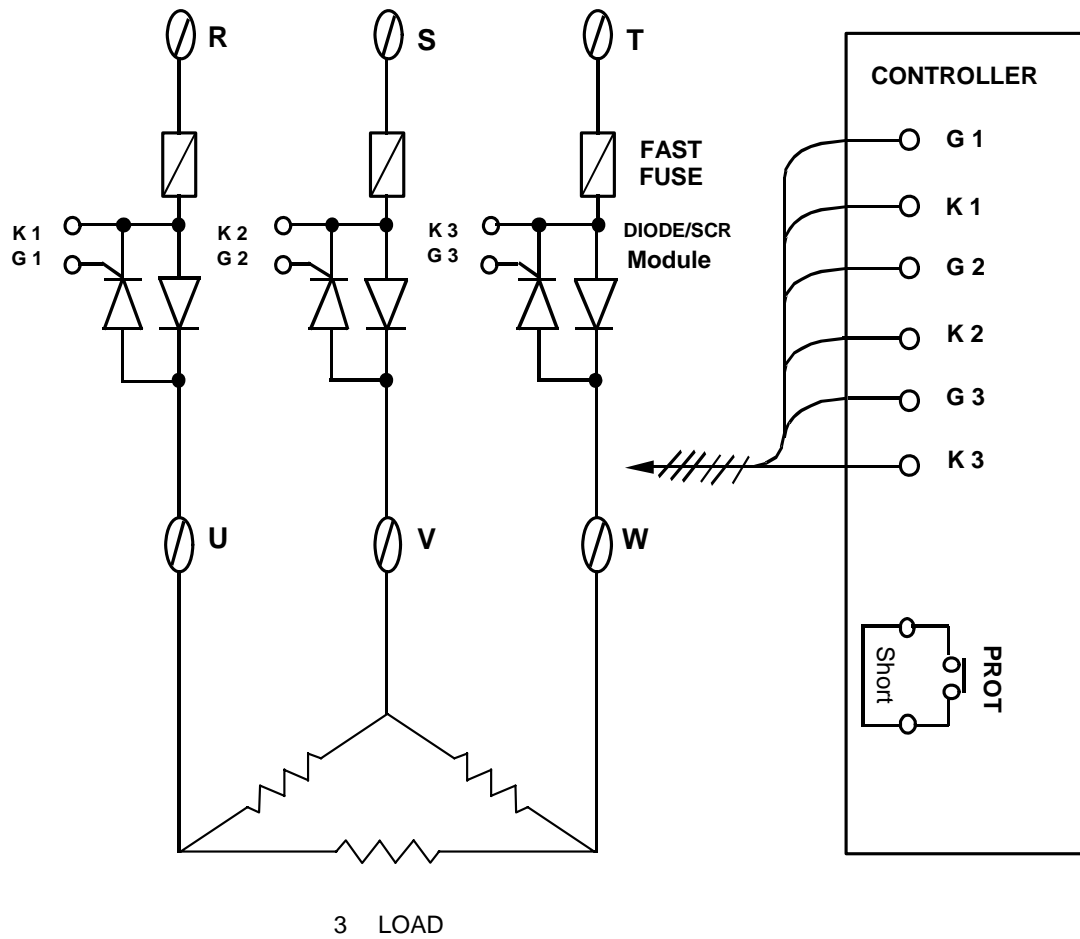

16.6 1 Zero crossing control (By SCR module)

- Available Models : FY900 / PFY900 , FY700 / PFY700
FY400 / PFY400
- OUT1: 1 SSR
- Parameter setting : OUTY=0
CYT1=1

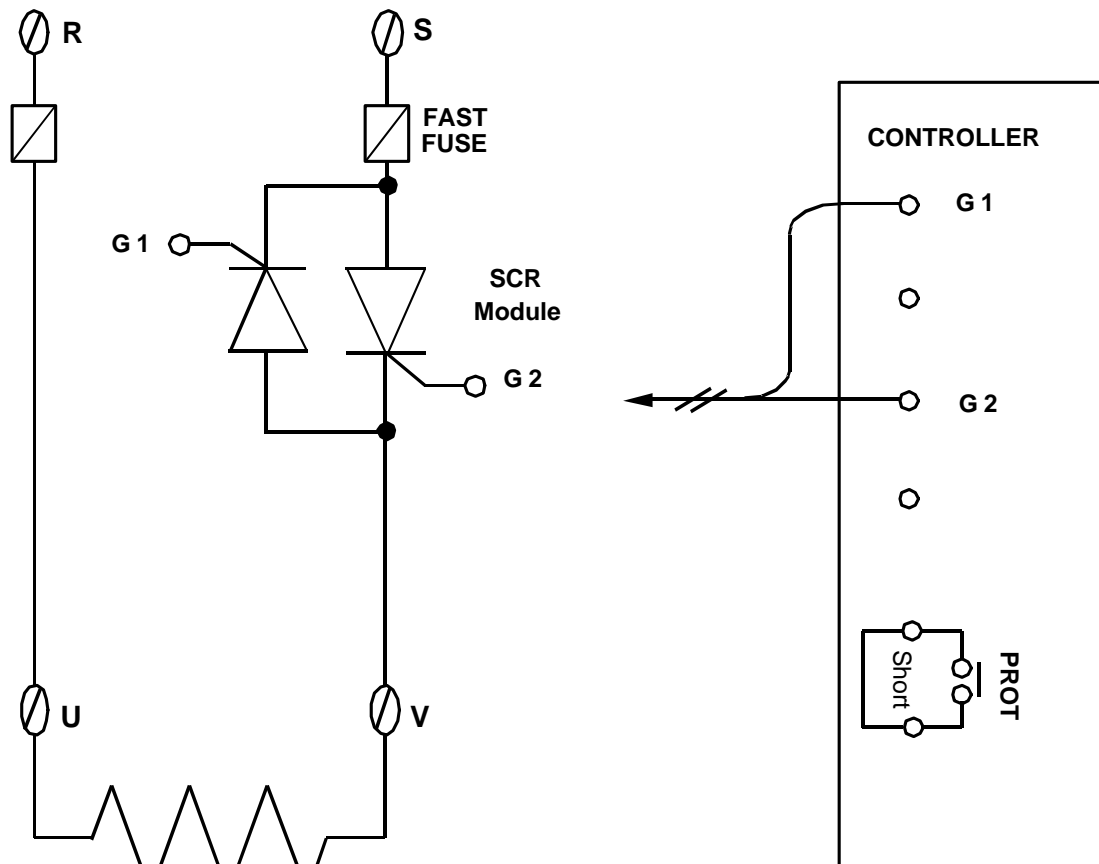

TIME CHART:

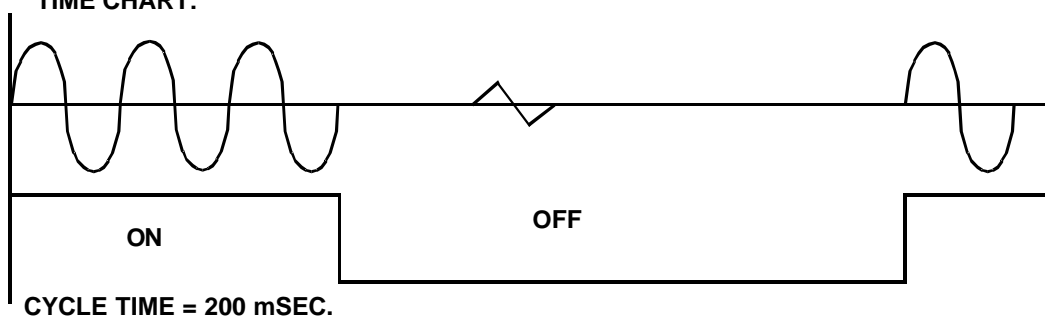

16.7 1 Zero crossing control (By TRIAC)

- Available Models : FY900 / PFY900 , FY700 / PFY700
FY400 / PFY400
- OUT1: 1 SSR
- Data Change : OUTY=0
CYT1=1

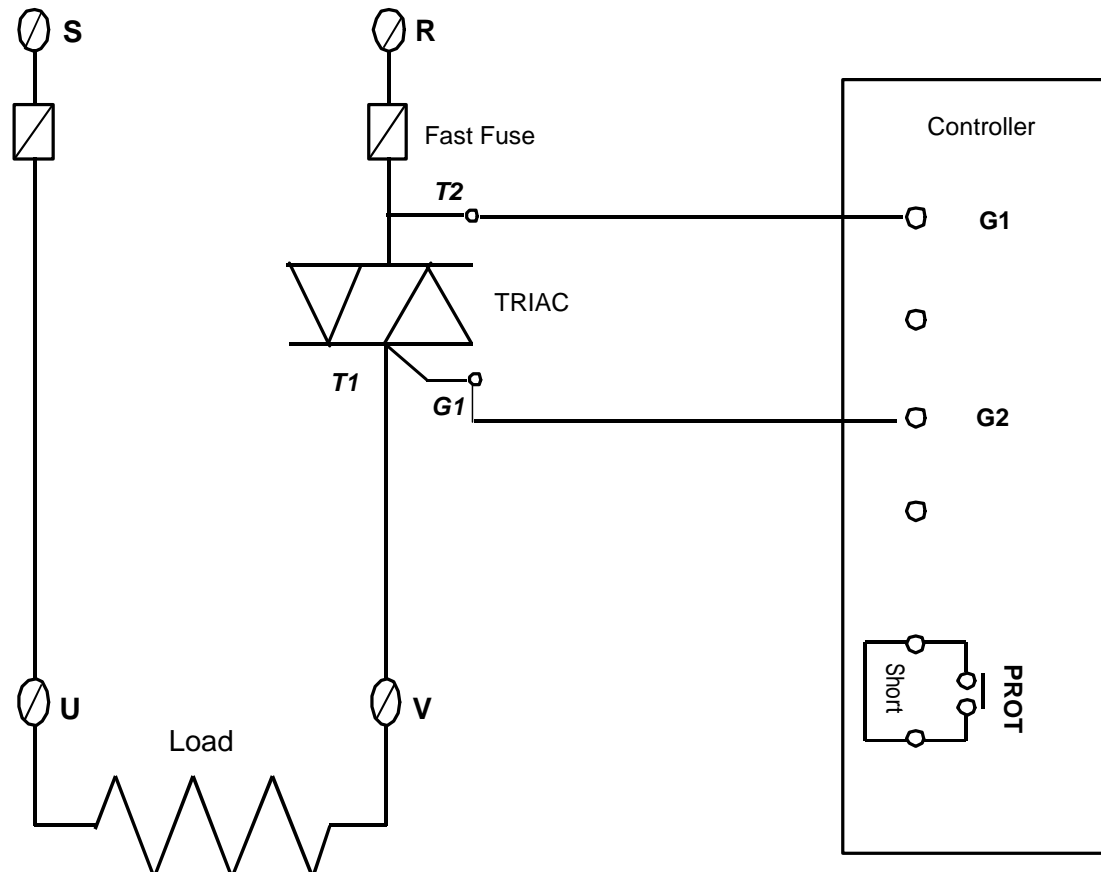

16.8 3 Zero crossing control (By SCR module)

- Available Models : FY900 / PFY900
- OUT1: 3 SSR
- Data Change : OUTY=0
CYT1=1

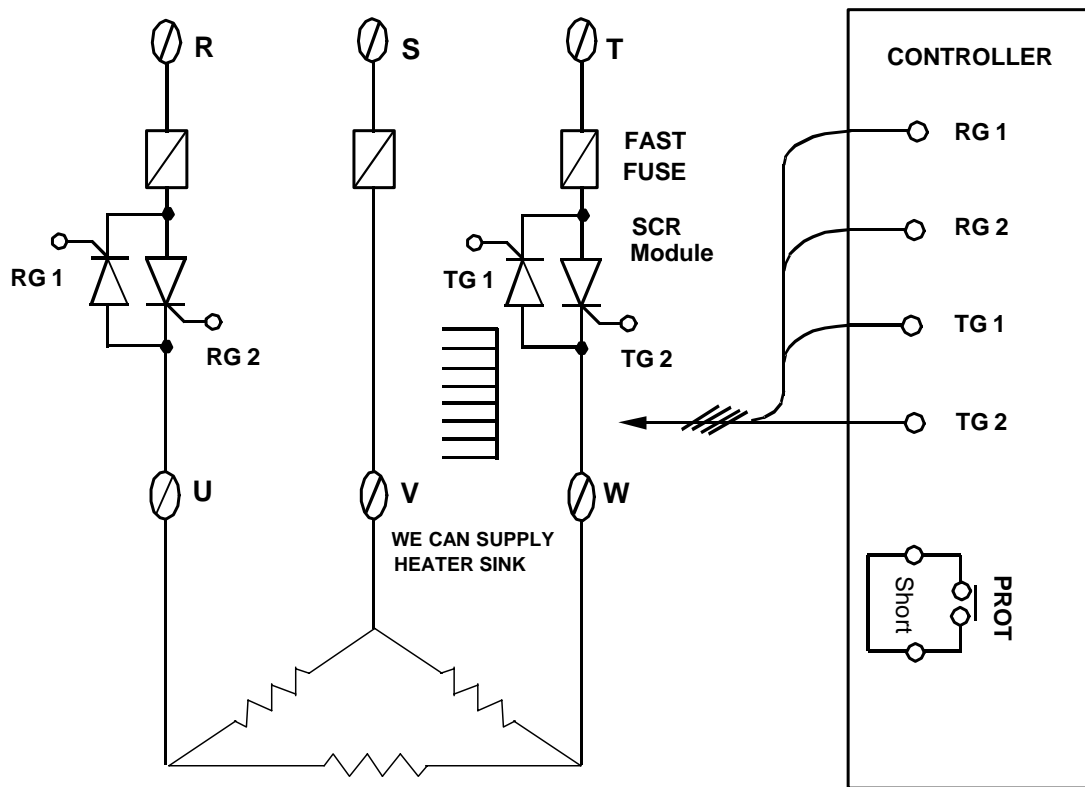

TIME CHART:

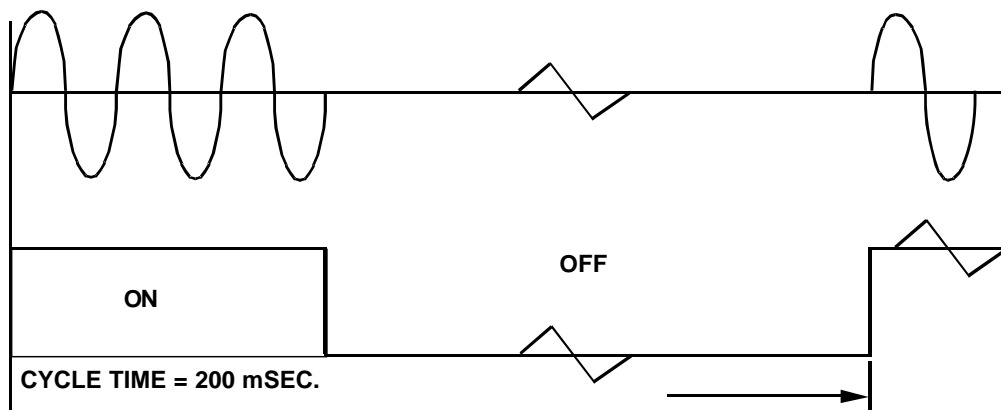

16.9 3 Zero crossing control (By TRIAC)

- Available Models : FY900 / PFY900
- OUT1: 3 SSR
- Data Change : OUTY=0
CYT1=1

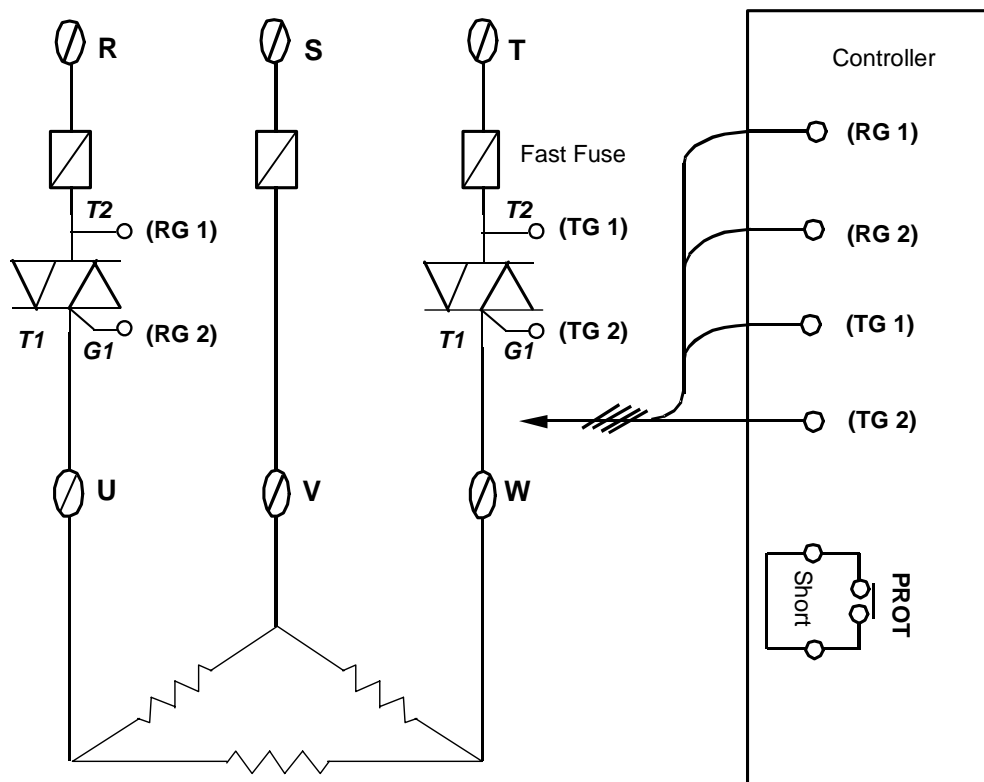

16.10 3 wires proportional motor valve control

- Available Models : FY900 / PFY900 , FY700 / PFY700
FY800 / PFY800 , FY600 / PFY600
FY400 / PFY400
- Data Change : OUTY=3
CYT1=1 ~ 100sec.
(Manufacturing default setting "5" seconds.)
RUCY=5 ~ 200 seconds.
 1. CYT1 is the cycle time of Open / Close
 2. RUCY is the 0 ~ 100% running time of motor valve

MOTOR VALVE

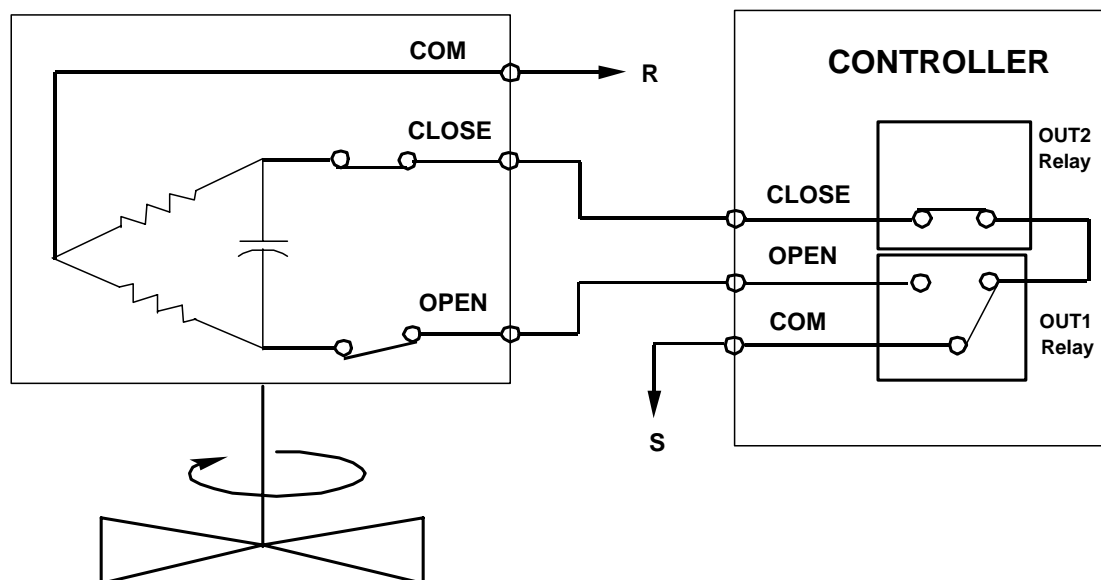

16.11 Communication

16.11.1 Protocol

- Interface RS-232 or RS-485 (by your order)
- Baud rate 110,300,1200,2400,4800,9600 bps
Choose by setting parameter "BAUD" in controller.

- DATA FRAME

Data Bits = 8 , ODD Parity , 1 Start bit , 1 Stop bit

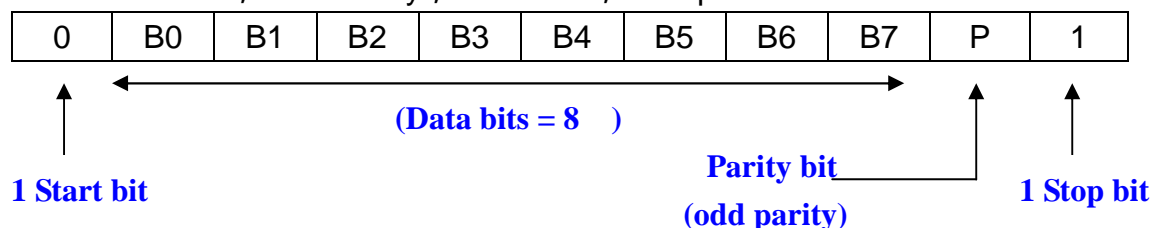

- DATA FORMAT

Use "HEX" code data format

NAME	DESCRIPTION	LENGTH	
CMD	Command	1 BYTE	↑ 7 Bytes ↓
XIDNO	The ID of controller	1 BYTE	
CHNO	Reservation , don't care	1 BYTE	
XADDR	Address	1 BYTE	
XDATA1	HIGH BYTE of DATA	1 BYTE	
XDATA2	LOW BYTE of DATA	1 BYTE	

- **CMD** R(READ from controller)
 M(MODIFY the data in controller temporarily)
 After controller restarted , the modification will be disappear
 W(WRITE the data to controller)
 The HEX CODE of R、 M、 W are as below
 R:52H , M:4DH , W:57H。

- **XIDNO** Range : 1(01 H)~100(63 H)
 Must be same as "IDNO" of the controller

- **CHNO** Range : (00 H ~ FF H)

- **XADDR** [See Appendix\(XADDR\)](#)

● Appendix(XADDR)

OPTION	XADDR	OPTION	XADDR	OPTION	XADDR	OPTION	XADDR
PV	80H	OUT8	20H	D2	42H	UNIT	64H
OUT%	A3H	SV_12	21H	CYT2	43H	SOFT	65H
SV	00H	TM_12	22H	HYS2	44H	CASC	66H
OUTL	01H	OUT12	23H	GAP1	45H	ODD	67H
AT	02H	SV_22	24H	GAP2	46H	OPAD	68H
AL1	03H	TM_22	25H	LCK	47H	HZ	69H
AL2	04H	OUT22	26H	INP1	48H	SET1	6AH
AL3	05H	SV_32	27H	ANL1	49H	SET2	6BH
PTN	06H	TM_32	28H	ANH1	4AH	SET3	6CH
SEG	07H	OUT32	29H	DP	4BH	SET4	6DH
TIMR	08H	SV_42	2AH	LSPL	4CH	SET5	6EH
SV_1	09H	TM_42	2BH	USPL	4DH	SET6	6FH
TM_1	0AH	OUT42	2CH	ANL2	4EH	SET7	70H
OUT1	0BH	SV_52	2DH	ANH2	4FH	SET8	71H
SV_2	0CH	TM_52	2EH	ALD1	50H	SET9	72H
TM_2	0DH	OUT52	2FH	ALT1	51H	SET0	73H
OUT2	0EH	SV_62	30H	ALD2	52H	INP2	74H
SV_3	0FH	TM_62	31H	ALT2	53H	OUTY	75H
TM_3	10H	OUT62	32H	ALD3	54H		
OUT3	11H	SV_72	33H	ALT3	55H		
SV_4	12H	TM_72	34H	HYSA	56H		
TM_4	13H	OUT72	35H	CLO1	57H		
OUT4	14H	SV_82	36H	CHO1	58H		
SV_5	15H	TM_82	37H	CLO2	59H		
TM_5	16H	OUT82	38H	CHO2	5AH		
OUT5	17H	P1	39H	CLO3	5BH		
SV_6	18H	I1	3AH	CHO3	5CH		
TM_6	19H	D1	3BH	RUCY	5DH		
OUT6	1AH	DB1	3CH	WAIT	5EH		
SV_7	1BH	ATVL	3DH	SETA	5FH		
TM_7	1CH	CYT1	3EH	IDNO	60H		
OUT7	1DH	HYS1	3FH	BAUD	61H		
SV_8	1EH	P2	40H	SVOS	62H		
TM_8	1FH	I2	41H	PVOS	63H		

16.11.2 Wiring diagram

RS232 Connection Diagram

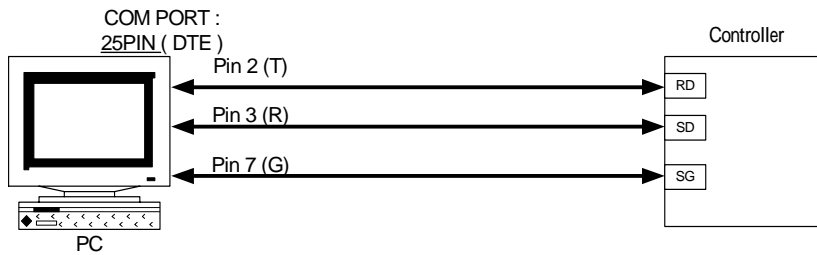
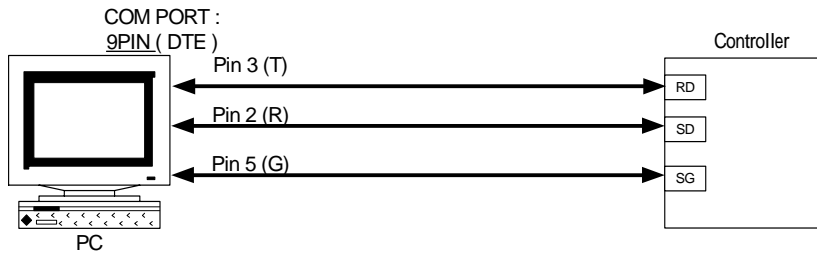

NOTE:

- 1.The length of cable be connected between controller and PC can't exceed 15 meter.
- 2.One Com Port can only be connected to one controller.
If more than one controller is connected to one Com Port , communication will be failed.
- 3.Ensure that the controller's IDNO and BAUD settings are the same with PC software's settings.
- 4.For the software communication format please refer to the "Protocol" file in CD.

RS485 Connection Diagram

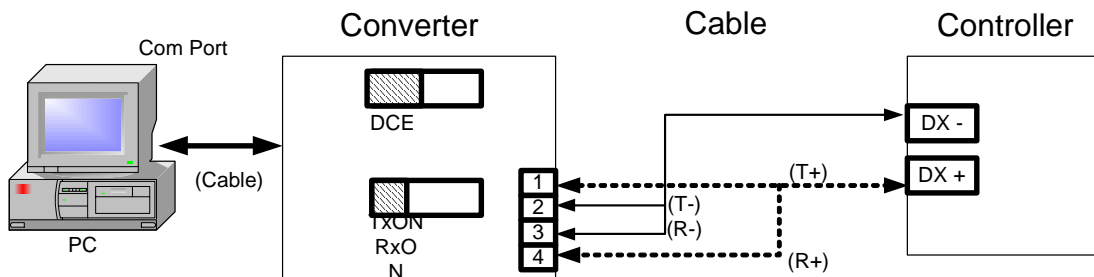

NOTE:

- 1.The length of cable be connected between Converter and Controller can't exceed 1.2 KM.
Suggestion:choose "Shielded Cable".
- 2.One Com Port can be connected up to a maximum of 30 Controllers.
- 3.Ensure that the Controller's IDNO and BAUD settings are the same with PC software's settings.
- 4.For the software communication format ,please refer to the "Protocol" file in CD.